

Henry & Sons Inc.

AC-20 / 30

Continuous Vacuum Stuffer



Operations and Parts Manual

Version 5.1

AC-20/30 Contents

Description	Section
General Information	1
Preventive Maintenance Schedule	2
Spare Parts List & Cost	3
Points of Interest	4
Cleaning Instructions	5
Hopper	6
Hopper Spring Assembly	7
Hopper Hold Down	8
Main Casting / Vacuum System	9
Angle Drive	10
Cam Drive	11
Cam Drive Housing	12
Transmission	13
Transmission / Clutch	14
Belt Tensioner	15
Motor / Controller	16
Vacuum Pump	17
Main Clutch	19
Electrical Panel	20
Electrical Diagrams	21
Troubleshooting	22



HENRY & SONS INC.

Ship to:
58480 Frudden Road
Bradley, CA 93426

Mail to:
PO BOX 3146
Paso Robles, CA 93447

Toll Free: 800.752.7507
FAX: 805.472.2626
www.dhenryandsons.com

Specifications Model AC-30/20

Feed Screw Speed 50- 600 rpm.*
Hopper Capacity: 95 - Gallons or 600 Pounds
Main Drive: 30hp.
Vacuum System: 2 HP Rietschle Thomas or Busch
Vacuum Specs: 2 hp, 35.3 cfm, with Overload Shutdown Protection
Main Frame: All Stainless Steel Const.
Main Body: All Stainless Steel Const.
Sanitation: All Feed Elements are Removable for Cleaning
Product Delivery Speed: 2000 - 45000 Pounds Per Hour **
Floor Space Required: 50" x 30"
Weight: Approx. 3000 lbs.

Electrical Data

Service Voltage: 480v
Control Voltage: 24v
Hz: 60
Fuse Rating: AC-30-50a AC-20-45a
Total Amps Required: 50
Cable Size: 4 - #10
All Allen-Bradley Control Components

** Depending on Product and Product Temperature These Figures Can Vary*

*** Depending on Feed Screws Selected*

HENRY & SONS INC. MODEL AC-20 /30 DIMENSIONAL DATA (ALL DIM'S IN INCHES)

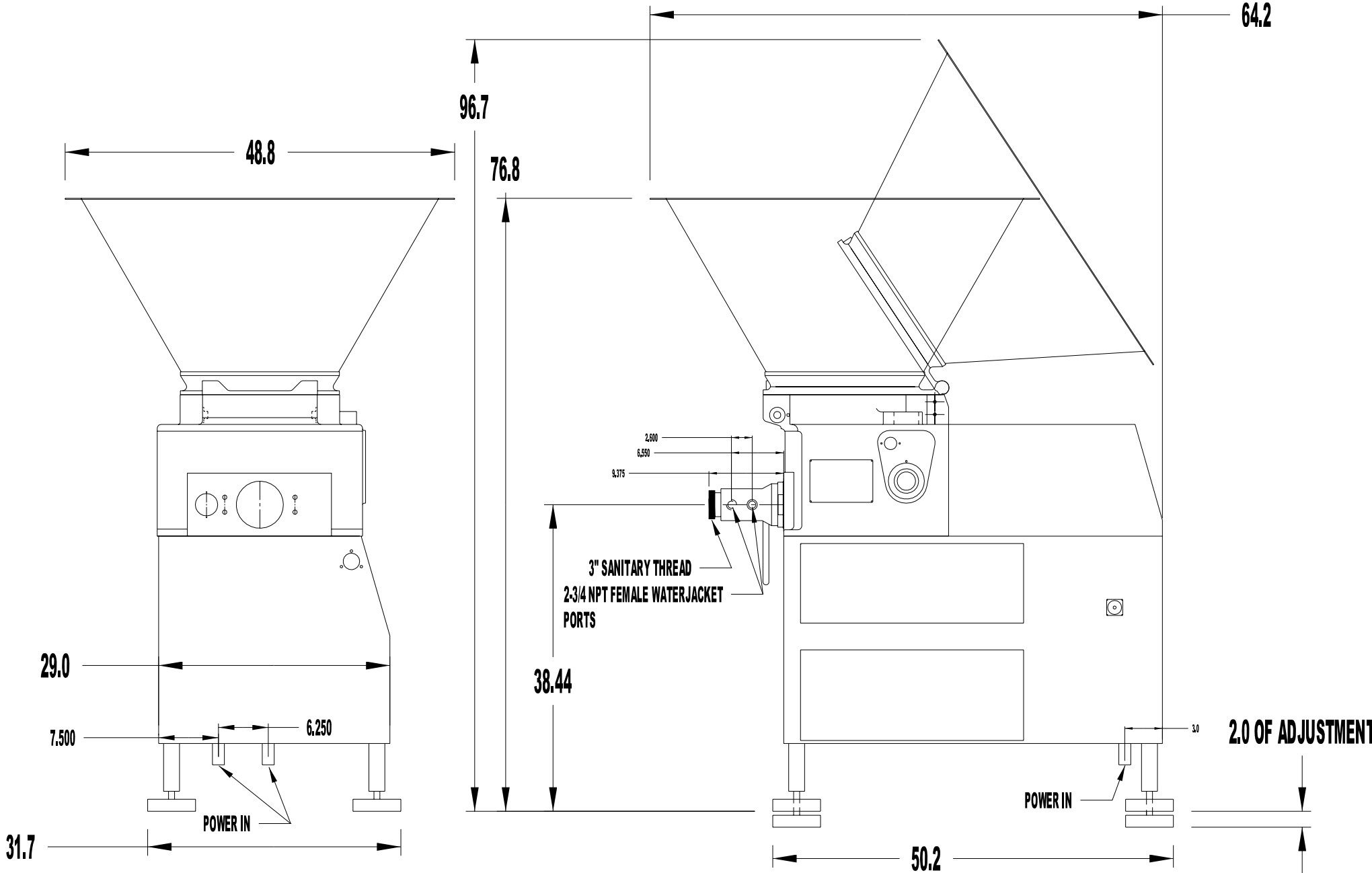

HENRY & SON INC. / AC-20 / AC-30 SCRAPER INSTALLATION INSTRUCTIONS

NOTE: REMOVE SCRAPER BEFORE OPENING HOPPER
(NEW STYLE SCRAPER)

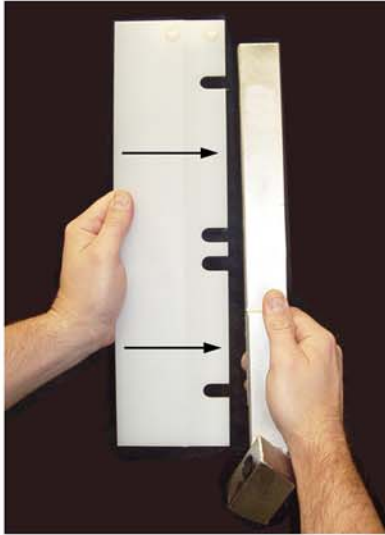

STEP # 1

INSERT SCRAPER INSERT INTO SCRAPER
ARM.



STEP # 2

SLIDE SCRAPER ARM BASE DOWN
ONTO SHAFT ON RING GEAR RECEIVING
BLOCK.



STEP # 3

CHECK TO MAKE CERTAIN THAT SCRAPER ARM BASE
SLIDES COMPLETELY DOWN SHAFT UNTIL BOTH BLOCKS
ARE TOUCHING.

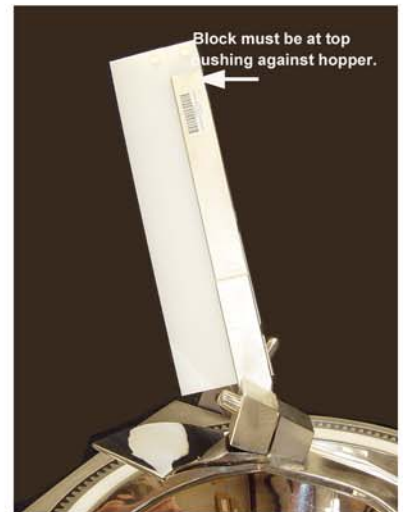

STEP # 4

THIS IS HOW THE SCRAPER
SHOULD APPEAR WHEN
INSTALLED CORRECTLY.



HENRY & SONS INC.

Ship to:
58480 Frudden Road
Bradley, CA 93426

Mail to:
PO BOX 3146
Paso Robles, CA 93447

Toll Free: 800.752.7507
FAX: 805.472.2626
www.dhenryandsons.com

Preventative Maintenance Schedule For H&S Stuffer Model (AC-20/30)

Daily Maintenance:

Clean vacuum system.

Grease zerk (opposite operator side) fittings every 2 hours of operation.

Weekly Maintenance:

Check oil level in main transmission gearbox, (fill to top of sight glass).

Check oil level in vacuum pump (if applicable).

Check Angle Drive chain tension / lube.

Check belt tension.

Visually inspect double screw drive seals for leakage, check both shafts for play.

Monthly Maintenance:

Change oil in main transmission gear box Oil type - 30 wt. Non-detergent
(recommended Chevron Gear Compound -100)

Busch Pump: Change oil / filter use BUSCH R-590 OIL

Rietschle Thomas pump: Change oil, use RIETSCHLE THOMAS SEMI
SENTHETIC OIL.

Check clutch adjustment.

Check brass gear for side to side play (use small pry bar lightly).

Check all fans.

Check brass guide ring for excessive wear (make sure that ring gear is not
touching funnel).

Check screw & housing wear (see website).

ANY QUESTIONS PLEASE CALL US TOLL FREE 1-800-752-7507

AC-20/30 Brass Guide Ring Wear Specifications

Checking the wear on the brass ring should be done using the following procedure.



Fig A

Brass Ring Thickness:

- .545 in. 13.84 mm (new)
- .490 in. 12.45 mm (rotate 180 degrees)
- .475 in. 12.07 mm (discard & replace)

Checking the brass ring thickness:

1. Using a vernier caliper check thickness of brass ring near the brass gear (fig A).
2. Check the same measurement 180 degrees from the brass gear (fig b).
3. Using the thickness guide determine what fuction needs to be performed.

Removing the brass ring:

1. Remove both side panels on main casting (4 slotted countersunk screws in each panel).
2. Using a 10mm socket remove the 4 - 6mm hex bolts from underside of ring.
3. Using a large screw driver or small crow bar gently pry the ring up out of the groove.



Fig B

Instalation of brass ring:

1. Clean groove and ring with degreaser, remove old silicone.
2. Apply a small amount of a good grade of silicone into bottom of groove.
3. Install ring into groove lining up the threaded holes in the underside of ring with the holes in the main casting.
4. Install bolts and tighten.



HENRY & SONS INC.

Ship to:
58480 Frudden Road
Bradley, CA 93426

Mail to:
PO BOX 3146
Paso Robles, CA 93447

Toll Free: 800.752.7507
FAX: 805.472.2626
www.dhenryandsons.com

Spare Parts List for Model AC-30

Qty	P/N	Description
1	114-080-002	Scraper Arm (New Design)
1	114-080-030L	Nylon Scraper Insert
2	114-050-030	Top Nylon Ring
2	114-050-040 AC	Bottom Nylon Ring
1	114-210-070	Brass Guide Ring
1	114-400-371	Brass Gear
1	555-008-025	815L Main Drive Belt
1	095-011-201	Angle Drive Chain
4	555-004-000	O-Ring for 455 Horn Holder
4	555-004-001	O-Ring for 367 80/90 Horn Holder
2	061-413-002	V-Ring (Vacuum System)
8	091-011-005	Carbon Brush
1	555-013-012	12v Power Supply
3	555-013-061B	3 Amp Fuse
3	555-013-061E	5 Amp Fuse
3	555-013-061I	10Amp Fuse
6	555-013-061T	50 Amp Fuse
1	112-300-004	Angle Drive (New) (Optional)
1	555-008-026	AB 30 HP Motor (Optional)
1	555-008-027	AB Powerflexx Drive (Optional)

POINTS OF INTEREST

MODEL AC 20/30



- 1. STOPPER
- 2. HOPPER LATCH
- 3. HOOD HOLD DOWN KNOB
- 4. VACUUM COVER
- 5. VACUUM GAUGE
- 6. HORN HOLDER
- 7. MAIN DISCONNECT
- 8. ALL STOP
- 9. MAIN MTR. "ON" BUTTON
- 10. VACUUM "ON" BUTTON
- 11. VACUUM DOOR

Cleaning Instructions AC- 20/30

1. Remove all product from hopper and feed screws
2. Turn off main switch
3. Remove scraper from ring gear (before opening hopper)
4. Tilt hopper back
5. Remove top nylon ring
6. Remove ring gear by pulling straight up then out towards front of machine
7. Remove bottom nylon ring
8. Remove horn holder
9. Remove double screw by screwing the “T” handle into the threaded hole in the double screw and pulling straight out
10. Remove double screw housing
11. Lift vacuum cover
12. Wash machine completely with low pressure hot water and appropriate soap
13. Reassemble machine using food grease on all o-ring connections and on double screws



Henry & Sons Incorporated
Model-AC-20/30 (Hopper)

	Part #	Quant	Description
1	555-001-002	1	Hopper (SST)
2	113-040-010	1	Pin
3	064-920-242	2	DU Bushing (MB 2015DU)
4	112-280-040	1	Pin
5	112-280-060	1	Handle
6	040-216-215	2	Bolt 16 X 45 SST
7	046-013-016	2	Washer 16 Flat SST
8	555-001-010S	1	Spiral Stopper
9	555-001-010F	?	Flat Stopper
10			

(Hopper Spring Assembly)

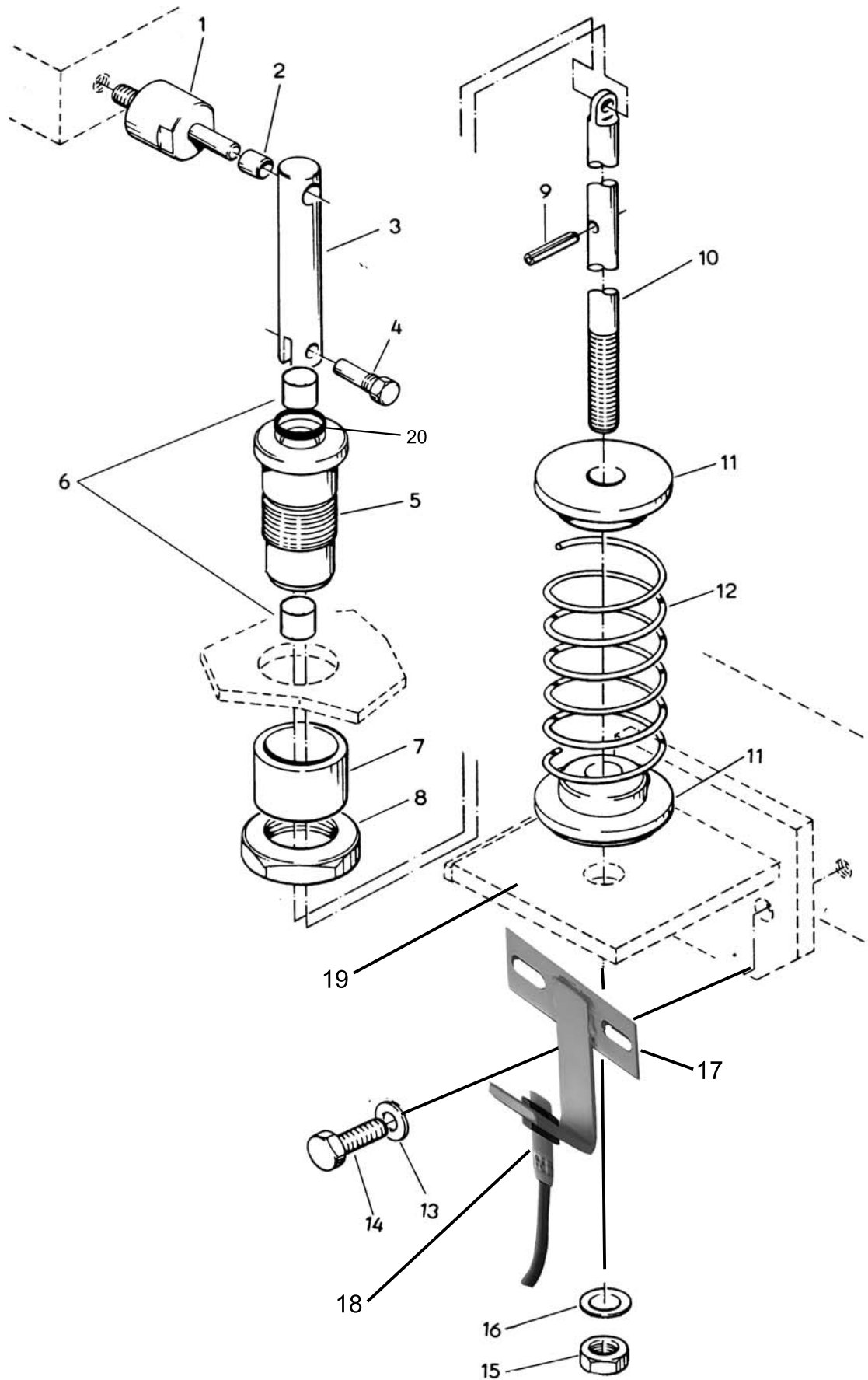

Henry & Sons Incorporated

Model-AC-20/30(Hopper Spring Assem)

Pict. #	Part #	Quant	Description
1	113-040-010	1	Pin
2	064-920-121	1	DU Bushing
3	113-040-051	1	Clevis
4	113-040-060	1	Shank Screw
5	113-040-080	1	Bearing Bushing
6	113-040-080A	2	DU Bushing
7	113-040-090	1	Spacer
8	045-640-160	1	Shaft Nut
9	048-408-220	1	Split Pin 8 x 45
10	113-040-120	1	Tension Rod
11	115-280-120	2	Bushing
12	115-280-170	1	Spring
13	046-010-010	2	Washer 10 mm
14	040-210-130	2	Hex Head Bolt 10 x 25
15	045-016-060	1	Hex Nut 16 mm
16	046-013-016	1	Flat Washer 16 mm
17	555-001-007	1	Prox Hopper Safety Switch Holder
18	555-013-066	1	Prox Hopper Safety Switch
19	113-041-000	1	Angle Bracket Complete
20	113-040-080B	1	Seal

(Hopper Hold Down Assembly)

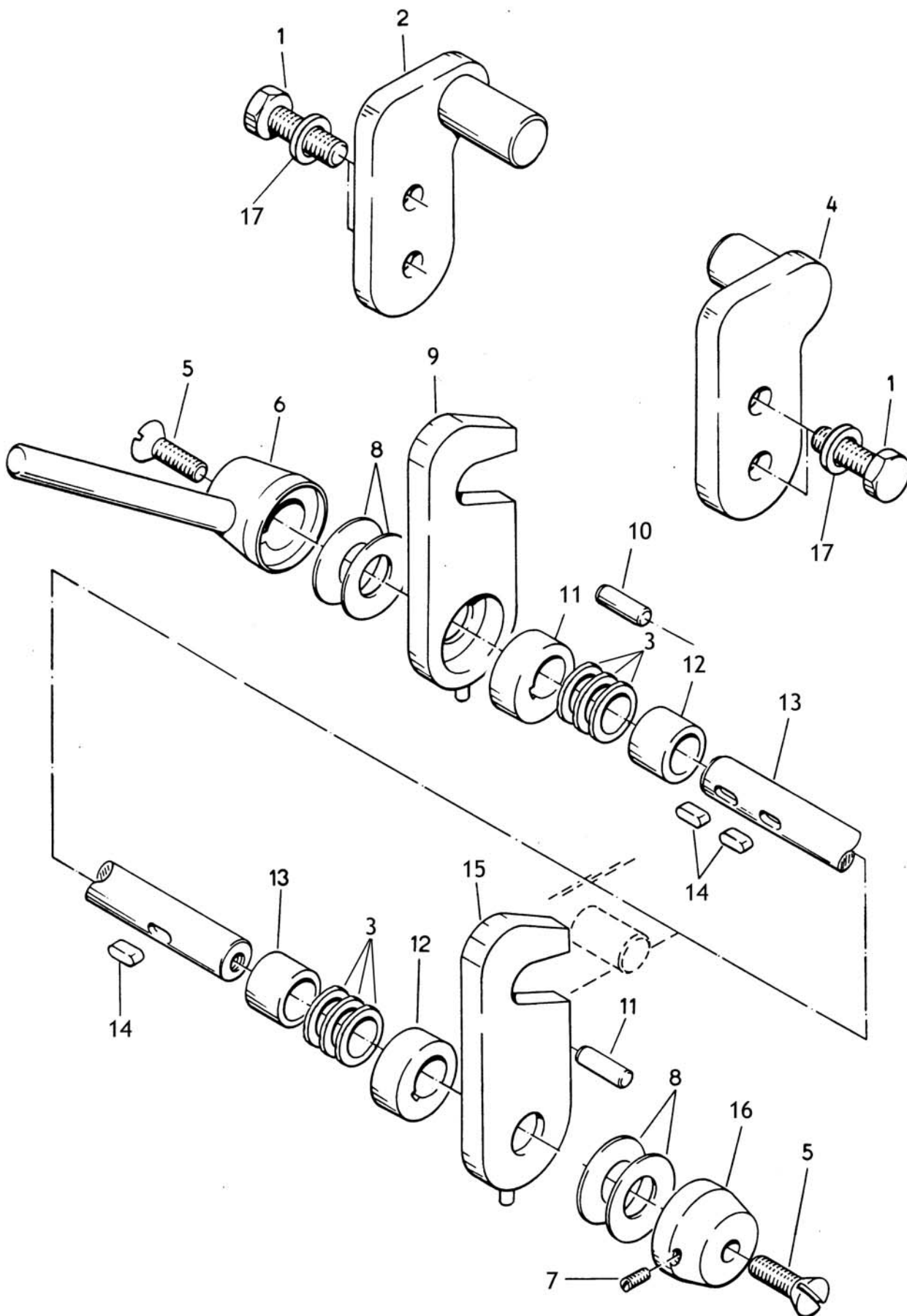

Henry & Sons Incorporated

Model-AC-20/30(Hopper Hld Dn Assem)

Pict. #	Part #	Quant	Description
1	040-212-175	4	Hex Head Bolt SST 12 X 35
2	112-280-550	1	Hinge
3	049-740-200	6	Spacer RingSST
4	112-280-500	1	Hinge
5	042-010-155	2	Countersunk Screw 10 X 30 SST
6	112-280-110	1	Lever
7	044-106-050	1	Set Screw 6m X 10m SST
8	066-804-003	4	Belleville Washer SST
9	112-280-170	1	Latch, Left
10	047-710-170	2	Pin 10 X 30 SST
11	112-280-150	2	Eccentric
12	064-920-201	2	Bushing MB 2015 DU
13	112-280-180	1	Shaft
14	049-006-040	3	Key 6 x 6 x 12
15	112-280-160	1	Latch
16	112-280-140	1	Hub
17	046-013-010	4	Flat Washer 12 mm SST
18			

(Main Casting)

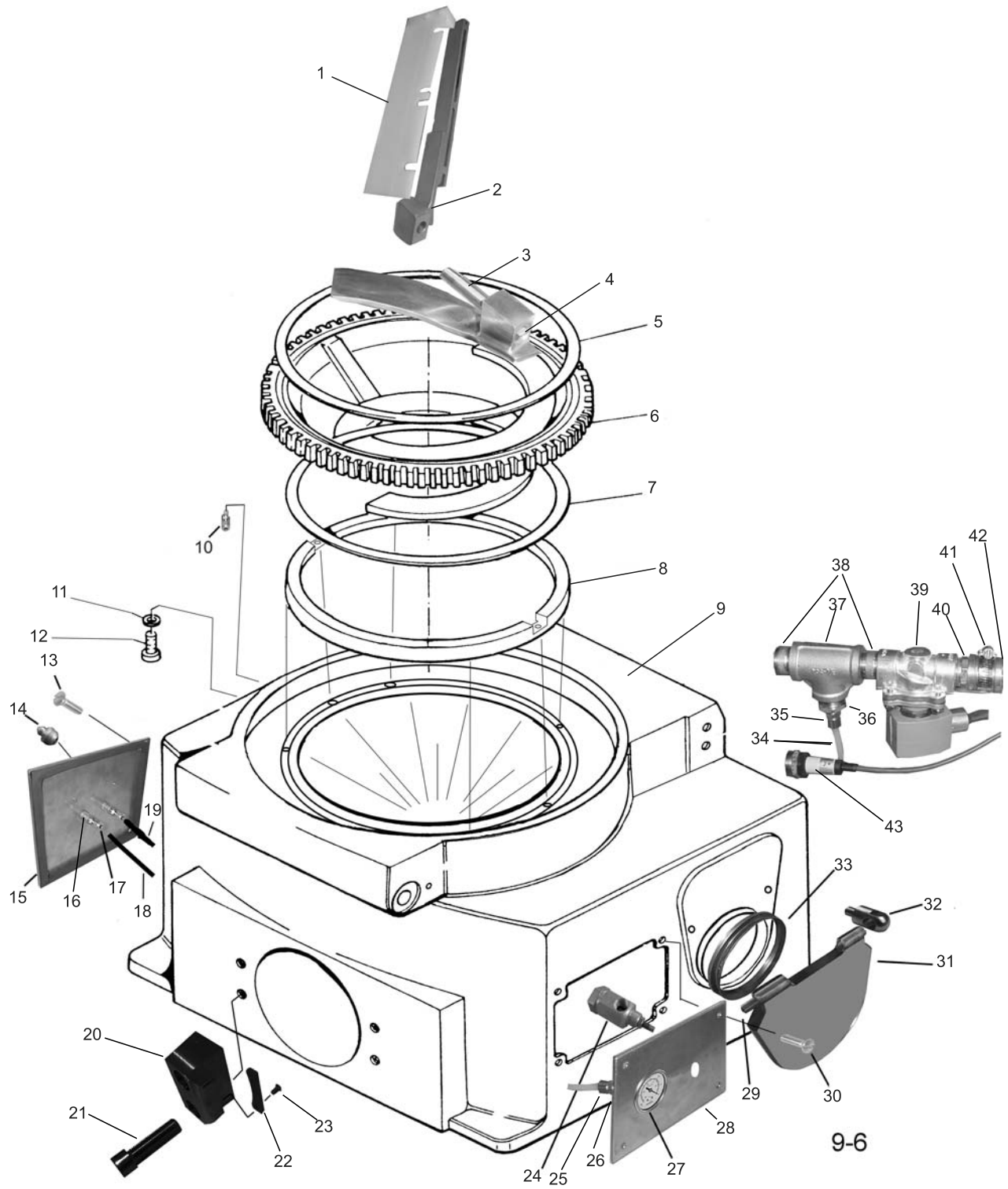

Henry & Sons Incorporated
(version 4.1)
Model-AC-20/30 (Main Casting)

Pict. #	Part #	Quant	Description
1	114-080-030L	1	Scraper Insert (Long)
2	114-080-002	1	Scraper Holder (New Style)
3	114-080-004	1	Receiving Block Shaft
4	040-210-140	1	Hex Head Bolt 10 X 35 SST
5	114-050-030	1	Top Nylon Ring
6	114-050-001	1	Ring Gear (New Style)
7	114-050-040AC	1	Bottom Nylon Ring
8	114-210-070	1	Brass Guide Ring
9	555-001-001	1	(MC-100) SST Main Casting
10	555-009-340	2	Nylon Tube Fitting
11	046-506-010	4	Lock Washer 6 mm SST
12	040-906-115	4	Hex Head Bolt 6 X 30 SST
13	041-906-116	4	Countersunk Screw 6 X 25
14	555-009-325	2	Zerk Fitting
15	555-009-330	1	Grease Panel
16	555-009-325A	2	1/8" NPT SST Coupling
17	555-009-340	2	Nylon Tube Fitting
18	555-009-360	1	Poly Tube Short
19	555-009-350	1	Poly Tube Long
20	111-660-003	2	Locking Bracket
21	040-916-250	4	Hollow Head Bolt 16 X 60
22	110-650-033	2	Pressure Plate Curved
23	041-205-065	4	Countersunk Screw 5 X 12
24	555-009-315	Opt	Vacuum Valve
25	555-009-318	1	Compression Fitting
26	555-009-318A	1	1/4" SST Coupling

Henry & Sons Incorporated
(version 4.1)
Model-AC-20/30 (Main Casting)

Pict. #	Part #	Quant	Description
27	090-111-206M	1	Vacuum Gauge
28	555-009-320	1	Vacuum Panel
29	047-708-150	2	SST Pin 8 X 50
30	041-906-116	4	Countersunk Screw 6 X 25
31	555-009-311	1	Vacuum Cover
32	555-009-310	1	Vacuum Cover Mount
33	061-413-002	1	V-Ring
34	555-009-370	1	1/4 " Poly Tubing
35	555-009-318	1	Compression Fitting
36	555-009-323	1	Reducer
37	555-009-322	1	Tee
38	555-009-321	2	Nipple
39	555-013-070	1	Solenoid Valve
40	555-009-324	2	Hose Barb
41	555-009-316	2	Hose Clamp
42	555-009-319	1	Vacuum Hose
43	555-013-071	1	Vacuum Water Sensor
44			
45			
46			
47			

(Angle Drive)

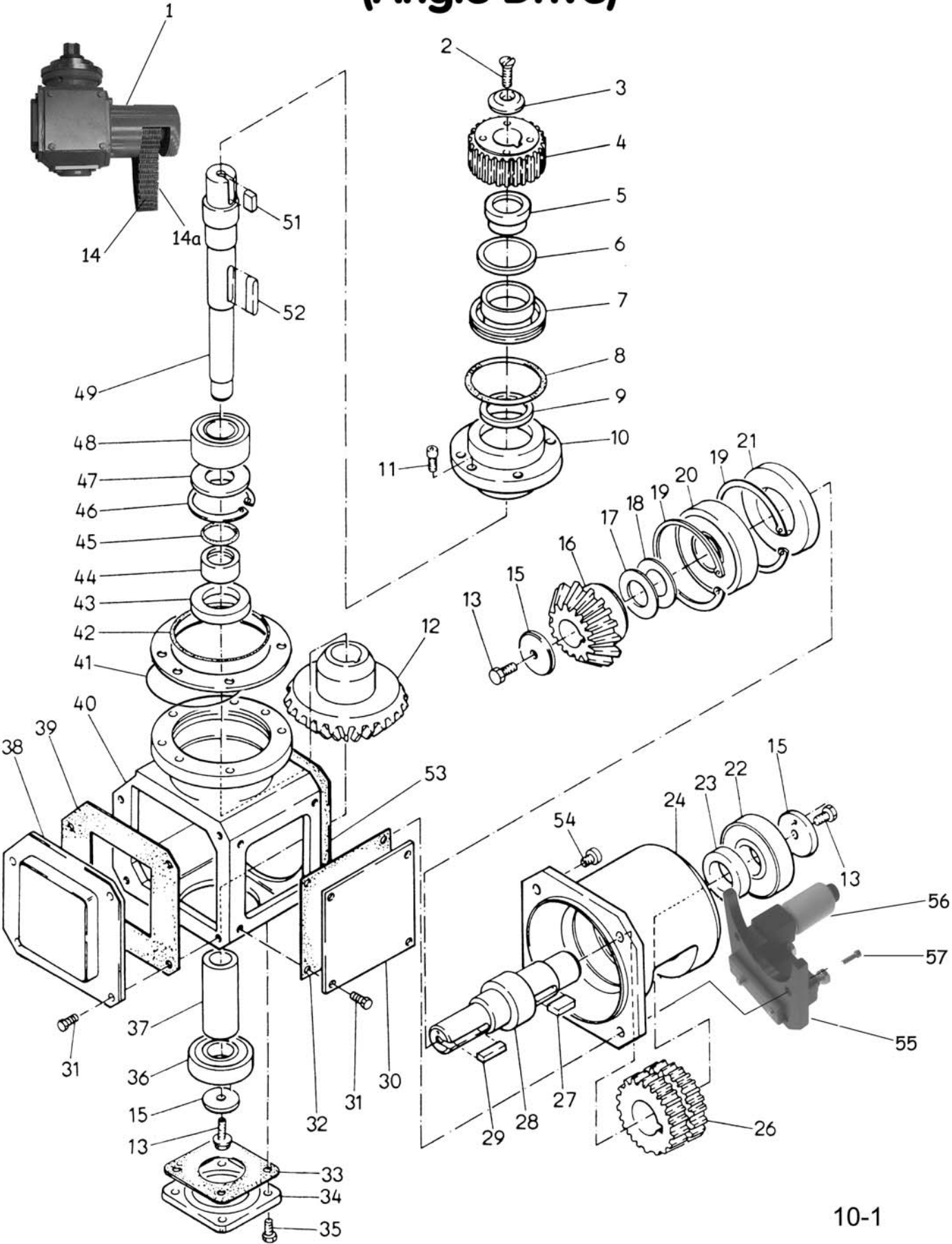

Henry & Sons Incorporated

Model-AC-20/30 (Angle drive-1)

Pict. #	Part #	Quant	Description
1	112-300-004	1	Angle Drive Assembly
2	041-808-585	1	Countersunk Screw 8 X 16
3	112-300-160	1	Washer Special
4	114-400-371	1	Brass Gear
5	112-300-030	1	Bushing
6	061-405-002	1	V-Ring Gasket
7	114-400-190	1	SST Gasket Sealing Flange
8	061-006-902	1	O-Ring 69.5 X 3
9	061-104-202	1	Oil - Seal 42 X 55 X 7
10	112-300-281	1	Bearing Cover
11	040-906-090	2	Hollow Head Bolt 6 X 16
12	112-300-250	1	Bevel Gear 30-Tooth
13	042-608-110	3	Tensilock Bolt 8 X 20
14	095-011-201	1	Angle Drive Silent Chain
14a	095-090-201a	1	Connecting Link
15	112-300-061	3	Washer
16	112-300-240	1	Bevel Gear 15-Tooth
17	049-750-250a	?	Shim .1 mm
18	049-740-250	1	Shim 3.2 mm Thick
19	049-320-720	2	Snap - Ring 72 X 2.5
20	063-063-061	1	Bearing 6306 2RS
21	061-104-014	1	Oil Seal 40 X 72 X 9
22	063-063-051	1	Bearing 6305 2RS
23	112-300-110	1	Distance Bushing
24	112-300-070	1	Sprocket Housing
26	112-300-090	1	Sprocket
27	049-010-101	1	Key 10 X 8 X 25

Henry & Sons Incorporated

Model-AC-20/30

(Angle Drive-2)

Pict. #	Part #	Quant	Description
28	112-300-081	1	Shaft (Short) 2 to 1
29	049-008-120	1	Key 8 X 7 X 32
30	112-300-130	1	Cover
31	040-206-090	8	Hex Head Bolt 6 X 16
32	112-300-230	1	Gasket
33	112-300-220	1	Gasket
34	112-300-140	1	Cover
35	040-206-060	4	Hex Head Bolt 6 X 12
36	063-063-051	1	Bearing 6305 2RS
37	112-300-051	1	Distance Bushing
38	112-300-121	1	Cover
39	112-300-211	1	Gasket
40	112-300-012	1	Gearbox Housing
41	112-300-290	1	Spacer
42	061-007-602	1	O-Ring 76 X 3
43	061-104-005	1	Oil Seal 40 X 62 X 7
44	112-300-042	1	Spacer
45	061-002-903	1	O - Ring 29.2 X 3
46	049-320-620	1	Snap - Ring 62 X 2
47	049-750-500	?	Shim .13 mm
48	063-332-061	1	Bearing 5206 2RS
49	112-300-021	1	Drive Shaft
50			
51	049-010-091	1	Key 10 X 8 X 22
52	049-008-139	1	Key 8 X 7 X 35
53	112-300-200	1	Gasket

Henry & Sons Incorporated
Model-AC-20/30

(Angle Drive-3)

Pict. #	Part #	Quant	Description
54	040-908-110	2	Hollow Head Bolt 8 X 20
55	555-002-000	1	Chain Idler Complete
56	555-002-001	1	Idler Sprocket 29 T
57	040-908-150	2	Hollow Head Bolt 8 X 30

(Cam - Drive)

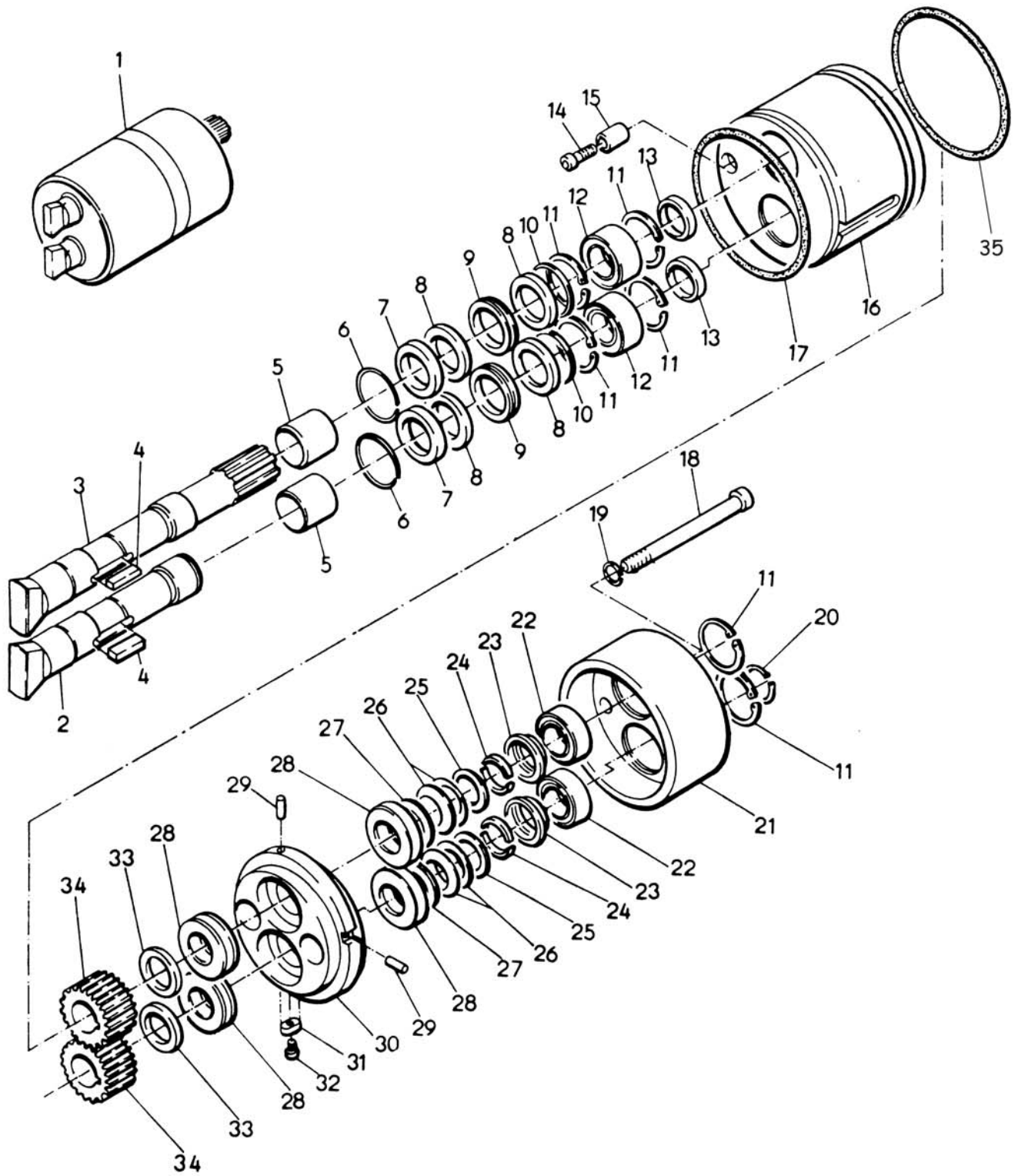

Henry & Sons Incorporated

Model-AC-20/30

(Cam – Drive-1)

Pict. #	Part #	Quant	Description
1	121-420-000	1	Double Screw Drive Assembly
2	121-420-030	1	Drive Shaft (Short)W/Pin Hole
3	121-420-020	1	Drive Shaft (Long)W/Pin Hole - Splined End
4	049-008-128	2	Key 8 X 7 X 34
5	111-220-030	2	Bushing
6	114-420-160	2	Round Wire Cir-clip
7	061-104-003	2	Oil Seal 40 X 52 X 8
8	061-104-001	4	Oil Seal 40 X 52 X 6
9	111-220-050	2	Ring With Holes
10	049-730-500	2	Spacer
11	049-320-520	8	Snap-Ring 52 X 2
12	064-203-201	2	Needle Bearing NA 49/32
13	121-420-110	2	Ring
14	114-420-570	1	Socket Head Cap Screw 10 X 34 SST.
15	114-420-560	1	Dbl. Screw Drive Line-Up Pin
16	121-420-012	1	Front Housing (3 Pc.)
17	061-011-901	1	O-Ring 119 X 5.7
18	040-912-410	2	Socket Head Cap Screw 12 X 140
19	046-512-160	2	Lock Washer 12mm
20	049-310-300	1	Snap Ring 30 X 1.5
21	121-420-271	1	Rear Housing (3 Pc.)
22	064-203-002	2	Needle Bearing NKIS 30
23	114-420-180	2	Bushing
24	114-420-170	2	Split Ring
25	049-740-300	2	Shim Disc
26	066-804-601	4	Roller Bearing Spring Washer

Henry & Sons Incorporated

Model-AC-20/30

(Cam - Drive-2)

Pict. #	Part #	Quant	Description
27	049-750-305	1	Shim 30 X 42 X .2
28	063-912-061	4	Thrust Bearing
29	555-005-002	2	Pin 3/8 X 1/2
30	121-420-201	1	Bearing Housing Center Piece
31	049-108-122	1	Key 8 X 5 X 32
32	041-603-040	1	Cheese Head Screw 3 X 8
33	064-827-002	2	Washer WS3047
34	114-420-140	2	Gear
35	555-005-003	1	O-ring 122 X 4

(Cam-Drive Housing)

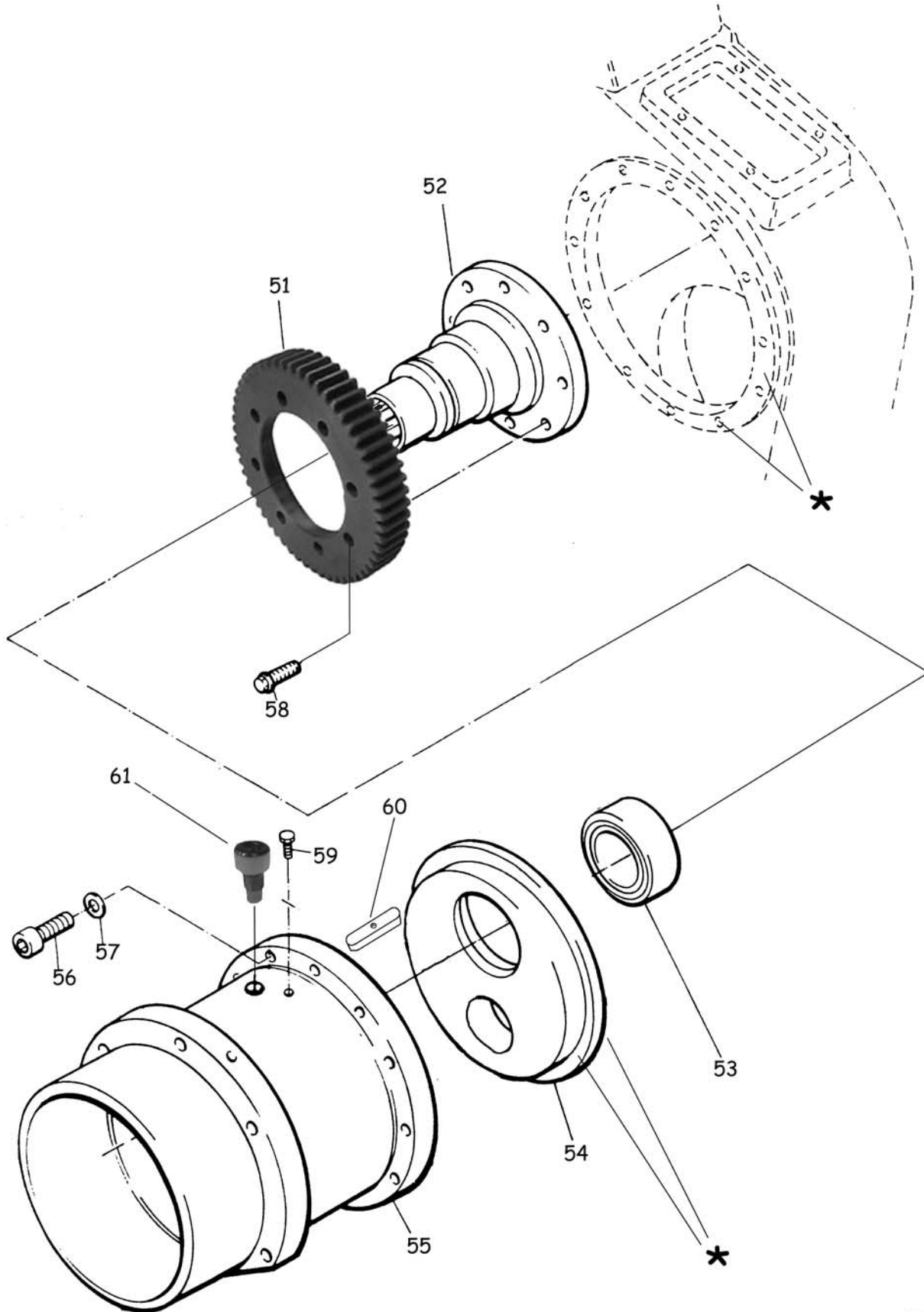

Henry & Sons Incorporated

Model-AC-20/30 (Cam-Drive Housing)

Pict. #	Part #	Quant	Description
51	111-460-040	1	Gear
52	114-410-170	1	Gear Hub
53	063-060-071	1	Bearing 6007
54	114-410-410	1	Bearing Housing
55	555-006-001	1	Cam - Drive Housing
56	040-908-150	12	Hollow Head Bolt 8 X 30
57	046-008-010	12	Washer
58	042-608-110	8	Tensillock Bolt 8 X 20
59	040-205-050	1	Hex Head Bolt 5 X 10
60	049-010-150a	1	Cam Drive Hsg. Locking Key
61	114-400-130	1	Cam - Drive Locking Bolt (Special)
*			Use Permatex Ultra Blue Sealant(Made by Loctite)

(TRANSMISSION)

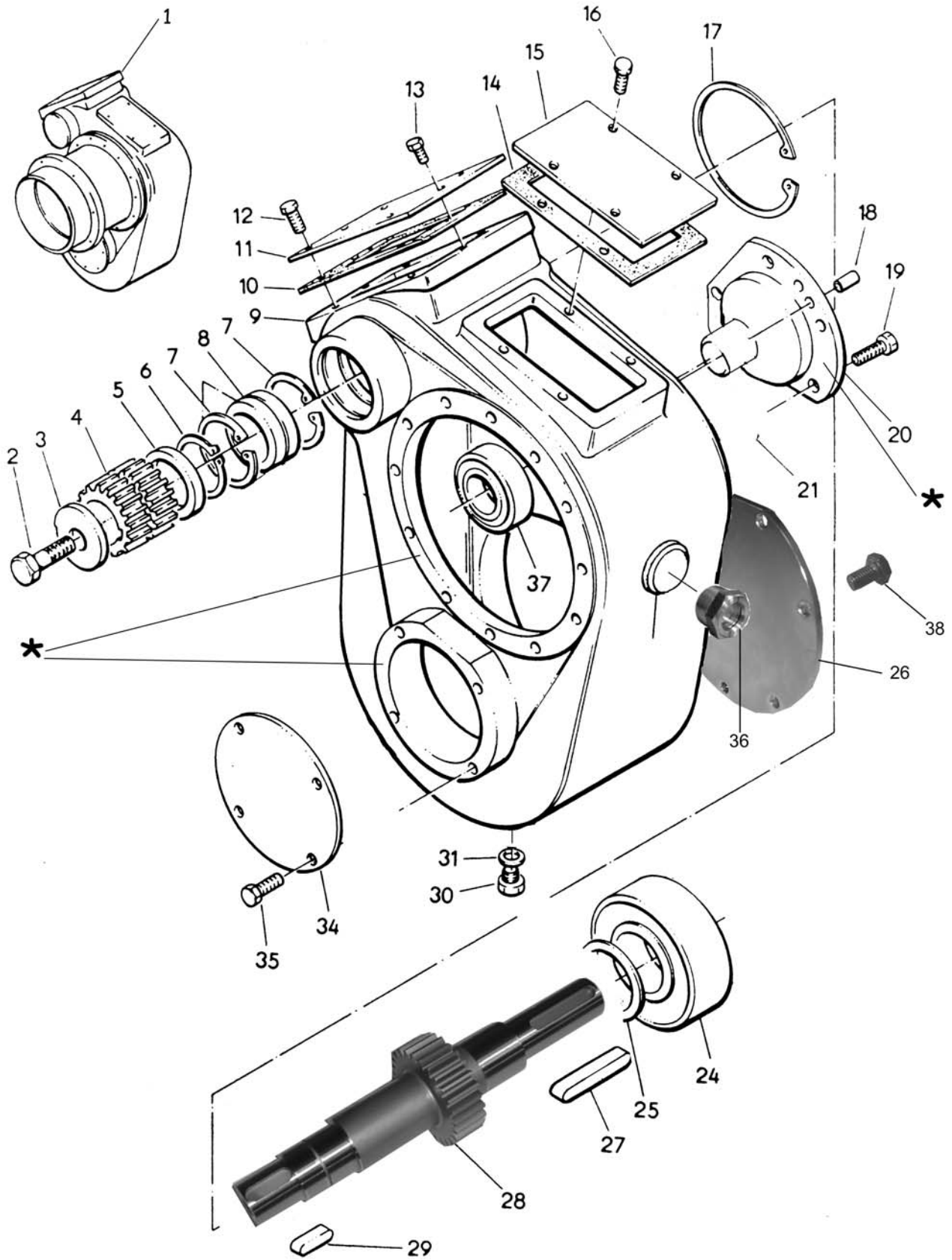

Henry & Sons Incorporated

Model-AC-20/30 (Transmission-1)

Pict. #	Part #	Quant	Description
1	555-006-006	1	Transmission Complete
2	042-608-110	1	Tensillock Bolt 8 X 20
3	112-300-061	1	Washer
4	112-300-090	1	Sprocket
5	061-103-501	1	Oil Seal 35 X 55 X 8
6	049-310-350	1	Snap Ring 35 X 1.5
7	049-320-550	2	Snap Ring 55 X 2
8	064-203-502	1	Needle Bearing 4907
9	555-006-000	1	Transmission Housing
10	112-220-230	1	Gasket
11	555-006-003	1	Trans Cover(2.8 X 5.62 X .25)
12	040-206-050	5	Hex Head Bolt 6 X 10
13	111-220-270	1	Bolt 6 X 10 With air Hole
14	114-410-510	1	Gasket
15	555-006-002	1	Trans Cover(3.5 X 5.62 X .25)
16	040-208-110	4	Hex Head Bolt 8 X 20
17	049-320-900	1	Snap Ring 90 X 30
18	047-708-120	2	Pin 8 X 20
19	040-208-110	4	Hex Head Bolt 8 X 20
20	114-410-240	1	Bearing Lid
24	063-333-081	1	Bearing 5308
25	049-740-400	1	Spacer 40 X 50 X 2.5
26	555-006-005	1	Trans Cover
27	049-010-180	1	Key 10 X 8 X 63
28	114-410-010g	1	Shaft
29	049-010-120	1	Key 10 X 8 X 32

Henry & Sons Incorporated

Model-AC-20/30 (Transmission-2)

Pict. #	Part #	Quant	Description
30	043-016-260	1	Drain Plug 16 X 1.5
31	061-501-601	1	Gasket 16 X 20
34	555-006-004	1	Trans Cover (4.3 Dia)
35	040-208-110	4	Hex Head Screw 8 X 20
36	555-006-007	1	Oil- Sightglass
37	063-063-054	1	Bearing 6305
38	040-210-130a	6	Hex Head Bolt 10 x 16
*			Use Permatex Ultra Blue Sealant(Made by Loctite)

(Transmission/Clutch)

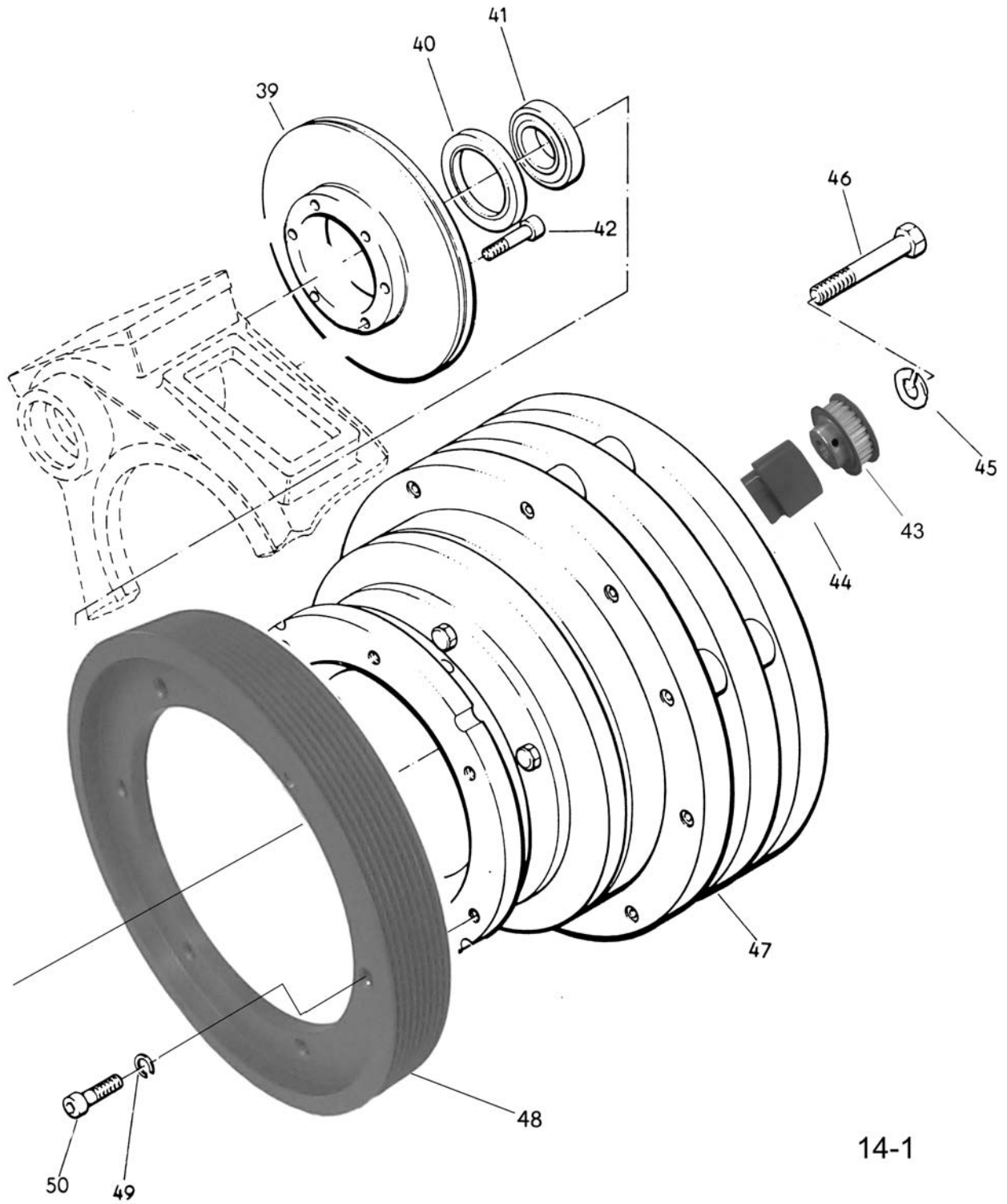

Henry & Sons Incorporated

Model-AC-20/30 (Transmission/Clutch)

Pict. #	Part #	Quant	Description
39	111-460-130	1	Brake Disc
40	061-105-001	1	Oil- Seal 50 X 65 X 8
41	111-460-120	1	Spacer
42	040-908-170	6	Hollow Head Bolt 8 X 35
43	555-013-023a	?	Pulley
44	555-013-026	1	Spacer
45	046-512-010	1	Lock Washer 12mm
46	040-112-430	1	Hex Head Bolt 12 X 150
47	091-011-201	1	Main Clutch
48	555-007-006	1	"L" Belt Pulley
49	046-510-010	1	Lock Washer 10mm
50	040-910-130	6	Hollow Head Bolt 10 X 25

(Belt Tensioner)

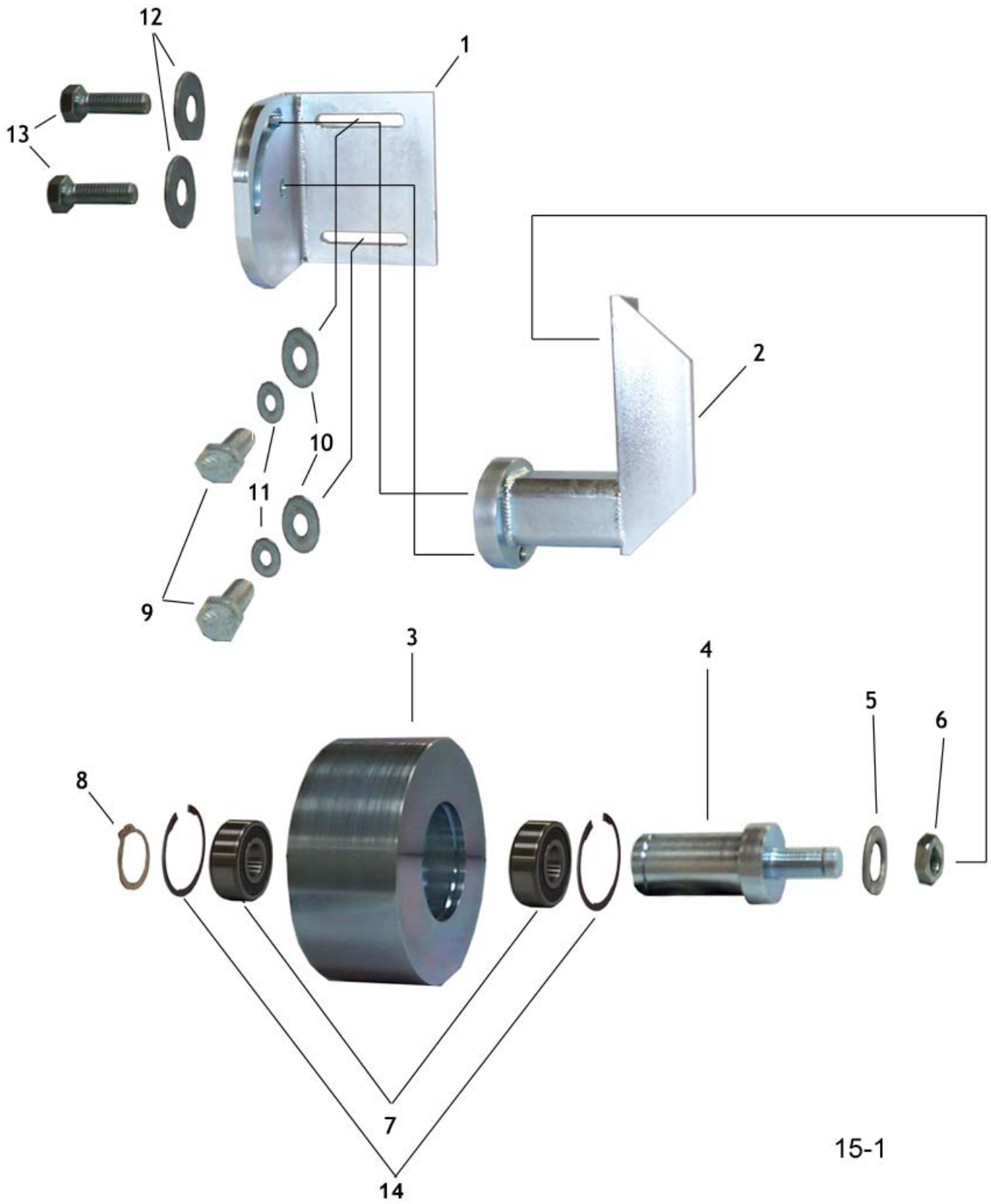

Henry & Sons Incorporated

Model-AC-20/30 (Belt Tensioner)

Pict. #	Part #	Quant	Description
1	555-008-003	1	Tensioner Base Bracket
2	555-008-004	1	Tensioner Roller Bracket
3	555-008-005	1	Tensioner Roller
4	555-008-006	1	Tensioner Shaft
5	555-008-012	1	½ " Lock Washer
6	555-008-006A	1	Nut ½ -20
7	555-008-007	2	Roller Bearing
8	555-008-009	1	Shaft Snap Ring
9	040-210-140	2	Hex Head Bolt 10 x 35 SST
10	046-013-000	2	10 mm Flat Washer
11	046-510-010	2	10 mm Lock Washer
12	555-008-011	2	½ "Flat Washer
13	555-008-010	2	½ "x 1- ½" Hex Head Bolt
14	049-320-620	2	Snap - Ring 62 X 2
15			
16			
17			

(Motor / Controller / Vacuum Pump)

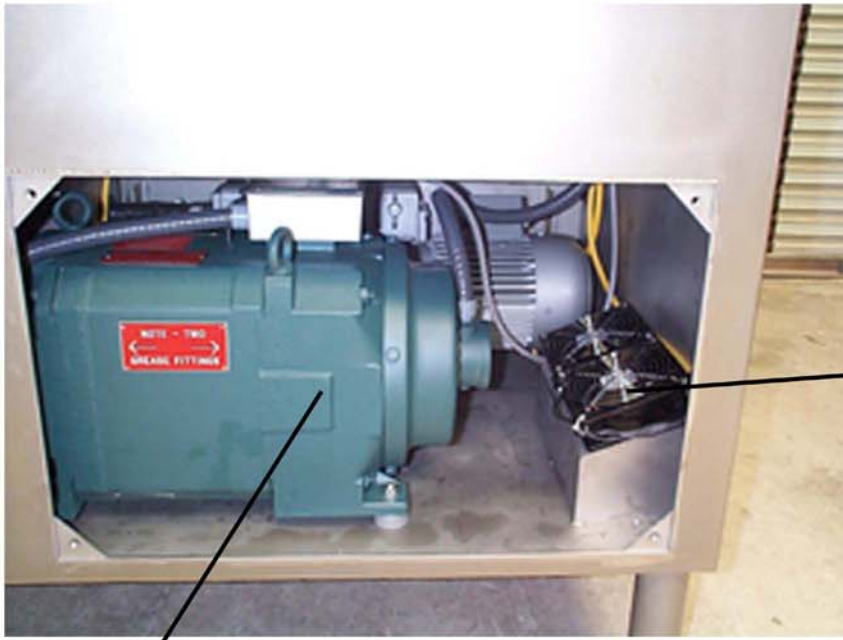

1

2



3

4



Henry & Sons Incorporated

Model-AC-20/30(Motor/Controller/ Vac Pmp)

Pict. #	Part #	Quant	Description
1	555-008-000	1	20 HP AC Motor (Reliance p/n P18I268)
	555-008-023	?	30 HP AC Motor (Reliance p/n P21R294)
2	555-013-013	6	Cooling Fan
	555-013-013A	6	Fan cover
3	555-008-0001	1	20 HP Controller (20V4260)
	555-008-024	?	30 HP Controller (30V4260)
4	555-009-004	1	2 HP Busch Vacuum Pump
5			
6			
7			
8			
9			

Motor / Controllers / Cooling Fans / Vac Pump



(ON THE MODEL AC-30 THIS CONTROLLER MOUNTS REMOTELY WITHIN 300' OF MACHINE)

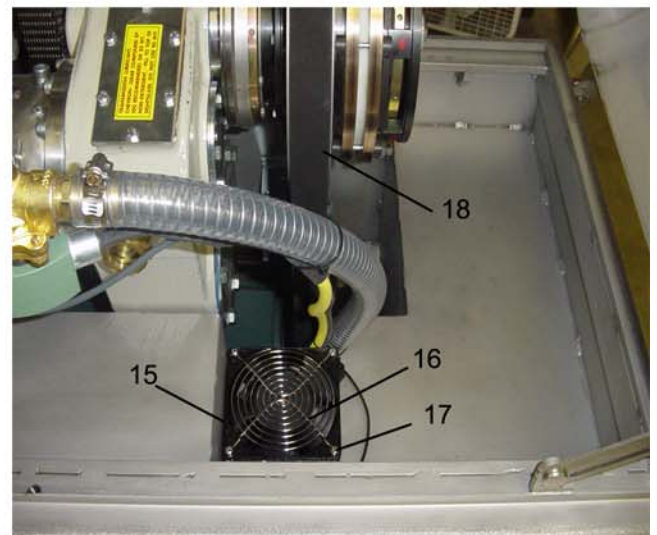
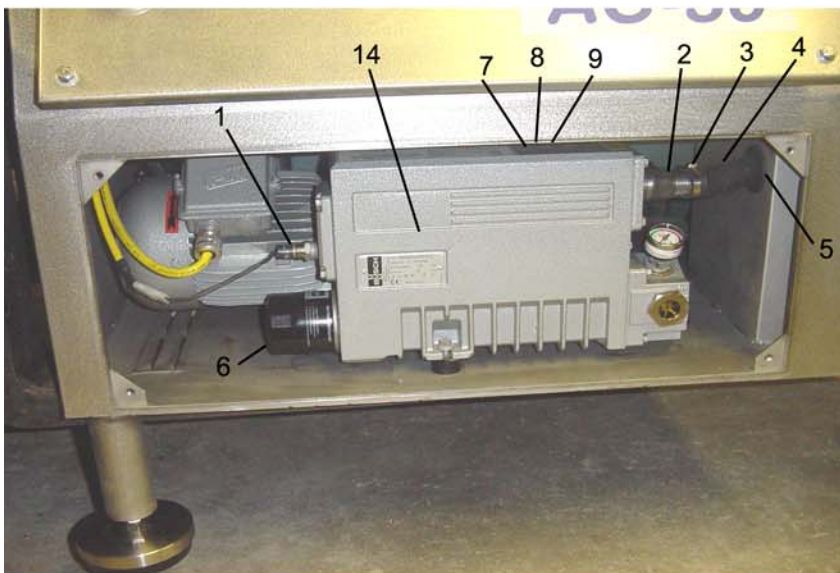

Henry & Sons Incorporated

(version 3.1)

Model-AC-20/30 (Mtr/VFD/Vac pmp/Fans)

Pict. #	Part #	Quant	Description
1	555-009-302	1	Temp Switch
2	555-009-328	1	Hose Barb
3	555-009-332	1	Hose Clamp
4	555-009-331	1	Exhaust Hose
5	555-009-329	1	Grommet
6	555-009-300	1	Oil Filter
7	555-009-327	1	Reducer
8	555-009-326	1	Street L
9	555-009-324	1	Hose Barb
10	555-013-073	1	Terminal Block
11	555-013-074	1	Terminal Block
12	555-008-026	1	30 HP AB Motor / 555-008-028 20 HP AB Motor
13	555-008-027	1	30 HP AB VFD / 555-008-029 20 HP AB VFD
14	555-009-004	1	Busch Vacuum Pump
15	555-013-013	4	Cooling Fan
16	555-013-013A	4	Cooling Fan Cover
17	555-013-013B	24	Cooling Fan Bolt
18	555-008-025	1	Belt (815) AC-30 / 555-008-022 (825) AC-20

BUSCH
U

INSTALLATION
AND
OPERATING MANUAL

R5 - SERIES
SINGLE STAGE ROTARY VANE
VACUUM PUMPS

TABLE OF CONTENTS

GENERAL

Identification
Operating Principles

1.0 INSTALLATION

1.1 Unpacking
1.2 Location
1.3 Power Requirements
1.4 Vacuum Connections
1.5 Oil Filling

2.0 OPERATION

2.1 Start-up
2.2 Gas Ballast
2.3 Stopping Pump
2.4 Water-Cooled Pumps
2.5 Oxygen Service Pumps

3.0 MAINTENANCE

3.1 Pump Oil
3.1.1 Oil Level
3.1.2 Oil Type and Quantity
3.1.3 Oil and Filter Change
3.2 Automotive-Type Oil Filter
3.3 Exhaust Filter
3.3.1 Filter Replacement
3.4 Vacuum Inlet Filter
3.5 Maintenance Chart
3.6 Overhaul Kit/Filter

4.0 TROUBLESHOOTING

5.0 LIMITED STANDARD AND EXTENDED WARRANTY

TECHNICAL DATA

MOTOR AND ELECTRICAL DATA

GENERAL

Identification

For model identification, see the nameplate mounted on the side of the exhaust box.

This manual is written to cover RA and RC versions of models 0025, 0040, 0063, 0100, and 0250 with a "C" or "E" appearing as the seventh character in the model type number stamped into the nameplate. For example it would appear as follows:

RAXXXX - CXXX - XXXX

When ordering parts, it is helpful to include the identification code stamped into the side of the cylinder as well as the serial number from the nameplate.

Operating Principles

All reference (Ref. XX) numbers listed in the text and on illustrations throughout this manual are related to the drawings and parts list near the center of this publication.

All R5 Series, Single Stage, Rotary Vacuum Pumps are direct-driven, air-cooled, oil-sealed rotary vane pumps which operate as positive displacement pumps. As Figure 1 shows, they consist of a rotor mounted concentrically on the drive shaft and positioned eccentrically in a cylindrical stator. The rotor has three radially sliding vanes which divide the pump chamber into three segments. The gas to be pumped enters at the inlet port (Ref. 260), passes through the inlet screen (Ref. 261) and the open anti-suck-back valve (Ref. 251) into the pump chamber. As the rotor rotates, the inlet aperture is closed, the gas is compressed and forced out through one-way valves between the pump cylinder and the exhaust box. This operation is repeated three times each revolution.

All R5 series pumps are designed to handle air. Vapor in the air stream can be tolerated when the pump is operated within certain operating parameters as defined by Busch, Inc. Engineering (see Section 2.2 Gas Ballast). When you desire to use the pump on an air stream that contains other vapor, contact Busch, Inc. Engineering for operating recommendations; otherwise, the warranty could be void.

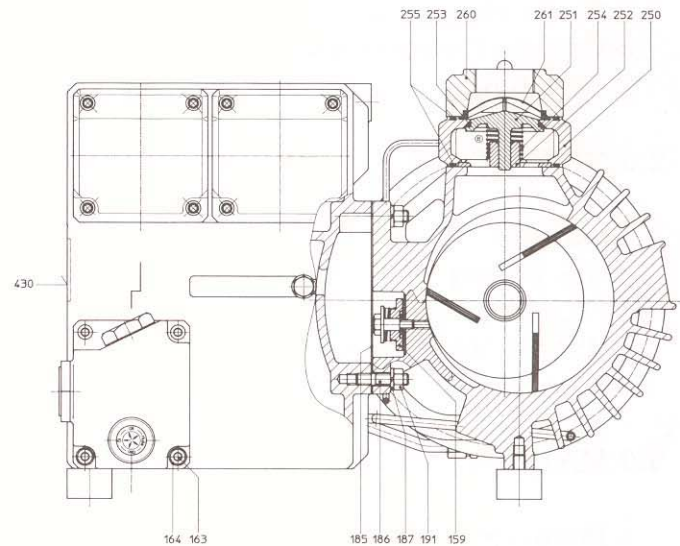

Figure 1 Module Cross Section

1.0 INSTALLATION

1.1 Unpacking

Inspect the box and pump carefully for any signs of damage incurred in transit. Since all pumps are ordinarily shipped FOB our factory, such damage is the normal responsibility of the carrier and should be reported to them.

Remove the nuts from the bottom of the box/crate and pull the pump out of the container, then unscrew the studs from the bottom of the rubber feet.

The inlet port of the pump is covered with a plastic cap prior to shipment to prevent dirt and other foreign material from entering the pump. Do not remove this cover until the pump is actually ready for connection to your system.

1.2 Location

The pump must be installed in a horizontal position on a level surface so that the pump is evenly supported on its rubber feet. Allow at least one foot (five feet for large pumps) of air space between the pump and any walls or other obstructions to the flow of cooling air.

Also, adequate ventilation must be provided for the fans on the pump and motor (i.e., do not locate the pump in a stagnant air location).

Whenever the pump is transported, be sure to drain the oil prior to shipping to avoid vane breakage when restarting the pump.

Do not tip the pump over if it is filled with oil.

Locate the pump for easy access to the oil sight glass (Ref. 83) in order to inspect and control the oil level properly. Allow clearance at the exhaust flange area to provide service access to the exhaust filters.

1.3 Power Requirements

The schematic diagram for the electrical connection is located in the junction box or on the nameplate of the pump motor.

The motor must be connected according to the electrical codes governing the installation. The power supply must be routed through a fused switch to protect the motor against electrical or mechanical overloads. The motor starter has to be set consistent with the motor current listed on the motor nameplate.

If the pump is supplied with a manual motor starter, it is preset at the factory in accordance with the customer's specification. For other voltage requirements, contact the factory for motor and/or starter information.

NOTE: See the motor manufacturer's manual for start-up maintenance of the motor.

Correct direction of rotation is marked by an arrow on the motor fan housing and is counter-clockwise when looking at the motor from the motor's fan side.

Caution: After the electrical connection has been made, but before the pump is filled with oil, the rotation of the motor must be checked. Open the inlet port and jog the motor briefly to make sure rotation is correct. If it runs backwards and if it is wired three phase power, reverse any two leads of the three at the power connection.

1.4 Vacuum Connections

Use a line size to the vacuum system that is at least as large as that of the pump inlet. Smaller lines will result in lower pumping speeds than the rated values.

Install a drip leg and drain on the vertical pipe near the pump inlet. Drain the drip leg often to prevent condensation from entering the pump.

Caution: The built-in anti-suck-back valve is not positive action; do not use it as a system check valve.

If more than one vacuum pump or a receiver tank is connected to a common main line, each pump should have its own manual or automatic operated shut-off valve or positive action check valve. The built-in anti-suck-back valve should not be used as a shut-off valve for the vacuum system.

Remove the plastic protective cap from the inlet port prior to connection of the pump to the system. Vertical connection of the vacuum line can be made directly to the pump inlet (Ref. 260).

The following threads are provided at the inlet of the R5 Series pumps:

Pump Size	Size	Threads
0025/0040	1 1/4"	Female NPT
0063/0100	1 1/4"	Female NPT
0250	2"	Female NPT

Should the gas that is pumped contain dust or other foreign solid particles, a suitable (5 micron rating or less) inlet filter should be connected to the inlet port. Consult the factory for recommendation.

1.5 Oil Filling

The pump is shipped without oil. After level installation, and after correct rotation has been established, fill the pump with recommended vacuum oil through the oil filling port (Ref. 88), the "MAX" and "MIN" position at the oil sight glass (Ref. 83).

Non-detergent oil should be used whenever possible. Additives in detergent oil will plug exhaust filter elements and shorten their life.

Busch recommends the R500 series oils be used in order to receive the best performance from your vacuum equipment. R500 series oil is a high quality vacuum oil that will give a longer running time between oil changes, provide better lubrication at high operating temperatures, and prolong the life of exhaust filter elements.

For general applications use:

R530 (with R590 as an upgrade for severe duty and R570 as an upgrade to a synthetic oil).

When Busch R500 series oils are used in new pumps, the pump will be covered by the extended provisions of the warranty (see last page).

SAE 30 weight non-detergent motor oil can be used in place of R530. New pumps are covered under the standard warranty provisions when the approved weight and type regular motor oil is used in them.

The following table gives the approximate quantities of oil required for each pump:

Pump Type	Oil Capacity (Qt.)
0025/0040	2.4/1.6
0063/0100	2.5/2.7
0250	7

Note: This table is for approximate values only. Use the sight glass oil level for the final oil level.

Caution: Do not add/fill oil with the pump running or through the exhaust/inlet ports.

For ambient operating temperatures lower than 5 degrees C (41° F), use Busch R580 synthetic oil or a multi-purpose motor oil with lower viscosity. Do not use detergent motor oil.

If this does not lower the viscosity sufficiently to permit starting, contact the factory. Oil detergent additives can cause the exhaust filters to become plugged and shorten their service life.

2.0 OPERATION

2.1 Start-up

Check rotation of the motor as described in paragraph 1.3 - Power Requirements.

Fill the pump with oil as described in paragraph 1.5 - Oil Filling.

Start the pump and immediately close the inlet. Run the pump for a few minutes before checking the oil level again. With the pump shut off, the oil level should be visible in the oil sight glass (Ref. 83), between "MIN" and "MAX" mark.

Add oil, if necessary. Pump oil should only be added when the pump is shut off and circulating oil has had sufficient time to return to the oil sump.

NOTE: *The oil separated by the exhaust filter element forms droplets on the outside of the exhaust filter which collect at a low point in the upper half of the exhaust box. From there, collected oil is drained back to the oil sump via an oil return valve (Ref. 275) which opens on RA models when the pump is shut off. It is necessary to shut off the pump (RA models only) after every 10 hours of operation to allow the check valve to open. If the pump is not shut off after this time period, it is possible to starve the pump of oil, and/or oil droplets may be blown out of the exhaust due to oil flooding in the exhaust chamber.*

On RC Standard model pumps, the collected oil is drawn continuously during operation of the vacuum pump to the inlet flange (Ref. 260) via the oil return line (Ref. 290). The oil return line is connected directly to the area of the exhaust box, downstream of the exhaust filter, which is at atmospheric pressure. Therefore, a constant amount of air is sucked into the pump which is an additional reason that the RC Standard Series pumps do not achieve as low a vacuum pressure as the RA Series vacuum pumps.

2.2 Gas Ballast

All RA Series pumps are equipped with a gas ballast valve. The gas ballast valve (Ref. 440) is located between the inlet port and the exhaust box. RA Series pumps up to size 100 are equipped with a permanent gas ballast which cannot be shut off unless the sintered filter is removed and the orifice plugged. Larger pumps are equipped with an adjustable gas ballast valve.

The adjustable gas ballast valve should normally be left open. Its primary function is to prevent water vapor from condensing in the pump. Condensation causes emulsification of the oil, loss of lubricity, and possible rotor seizure.

2.3 Stopping Pump

To stop the pump, turn off the power. The pump has a built-in anti-suck-back valve (Ref.

251 thru 255) to prevent the pump from rotating backwards when it is shut off.

Caution: Do not use the anti-suck-back valve as a check or shut-off valve for your vacuum system. Do not depend on the anti-suck-back valve to prevent pump oil from migrating through the inlet into the system, when the pump is shut down.

Install an automatic operated valve in front of the pump, if more than one pump is pumping on the same line or if there is a sufficient volume of vacuum in the system to cause the pump oil to be drawn into the piping when that pump is shut down.

All R5 Series pumps are vented internally to atmospheric pressure through venting holes which are next to the exhaust valve assembly.

2.4 Water-Cooled Pumps

Water-cooled pumps are cooled by circulating the oil through a shell-and-tube type heat exchanger. The circulation of the pump oil (through the shell) is uncontrolled, but the circulation of the cooling water (through the tubes) is thermostatically controlled. The flow rate of the cooling water is controlled by a thermostatically activated valve that senses (through a capillary bulb mounted in the exhaust box) the pump's oil temperature as it is discharged from the compression chamber. The valve will open at its set point and close at approximately 3° to 5°F below the set point. The valve set point is adjustable as follows:

(a) Rotate the valve adjustment screw counterclockwise to cause the valve to open at a higher temperature.

(b) Rotate the valve adjustment screw clockwise to make the valve open at a lower temperature.

The thermostatic valve can be manually opened by inserting a screwdriver under each side of the spring guide and prying the spring and guide upward away from the valve body.

2.5 Oxygen Service Pumps

Warning: This pump is filled with a special operating fluid. Do not use any other type of fluid, oil and/or grease. Use one of the following:

- Fomblin LC 250
- Tyreno Fluid 12/25V (perfluorinated polyether)
- KRYTOX ® Vacuum pump fluid by Du Pont Company

If you have any questions, please phone our Customer Service Department for more information.

Application

If this pump is contaminated by organic compounds do not attempt to use it on oxygen service until it has been decontaminated.

These Installation and Operating Instructions are valid for the following vacuum pumps:

RA/RC 0025
RA/RC 0040
RA/RC 0063

RA/RC 0100
RA/RC 0250

These pumps have been manufactured, solvent washed (to remove organic contaminants) and assembled according to the latest technical standards and safety regulations. If this pump is not installed properly or not used as directed, a dangerous situation or damage might occur.

It is mandatory that these operating instructions be read and understood prior to vacuum pump installation and start-up.

Pump Overhaul/Repair

Busch Inc. strongly recommends that all major repair operations be conducted at the factory. **Improper handling of repairs could result in extreme danger to personnel operating the pump.**

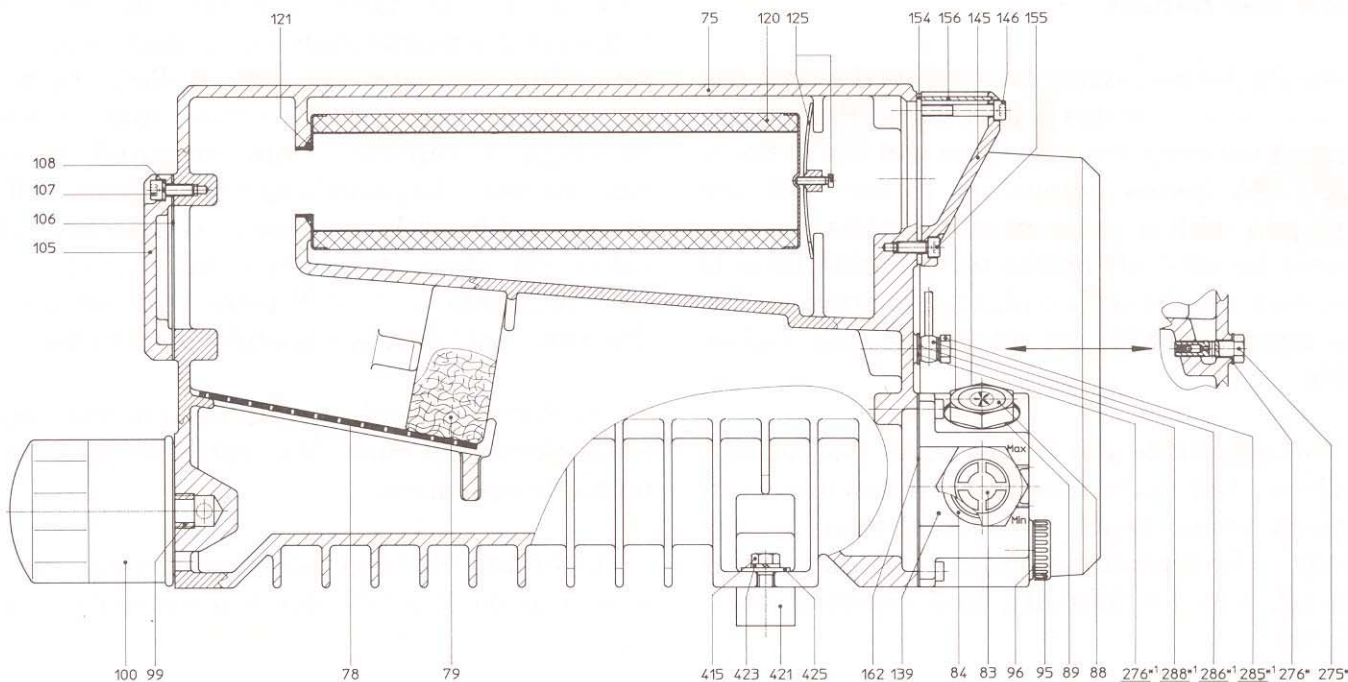

Figure 2 Typical Exhaust Box Cross Section

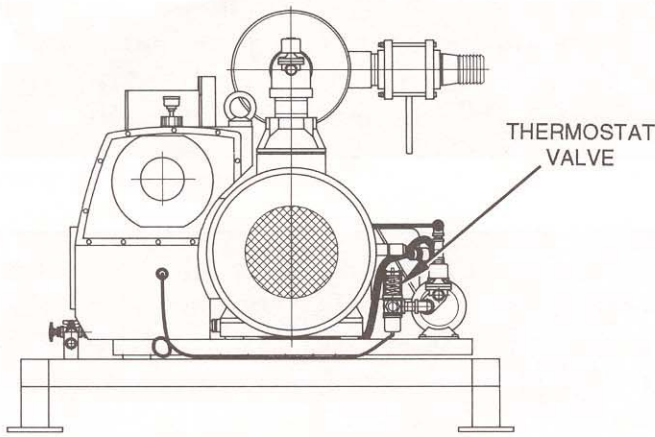

Figure 3 Water Cooled Pump

3.0 MAINTENANCE

R5 Series, single stage, rotary vacuum pumps require very little maintenance; however, to insure pump performance, it is recommended that the following steps be observed:

3.1 Pump Oil

3.1.1 Oil Level

With the pump shut off, make sure there is a sufficient amount of clean oil in the pump. The oil level should be observed on a daily basis. Replenish it if it drops below the "MAX" mark on the sight glass.

All oil level readings should be taken only when the pump is not running. Allow the oil to settle before adding any oil. The oil might appear to be foam which is a normal phenomenon with aerated oil.

Oil can be added to the oil fill port (Ref. 88) after the pump is shut off and the circulating oil has had sufficient time to return to the oil sump.

Caution: No oil should be added while the pump is running since hot unfiltered oil vapor may escape through the oil fill port.

Under normal circumstances, it should not be necessary to add or drain oil from the pump between recommended oil changes. A significant drop in oil level means there is an oil leak or that an exhaust filter is broken; in which case, the pump should be smoking excessively. It is normal for the oil to be foamy and light colored in an operating pump. However, if the oil is milky or dark colored, it is contaminated or burned and must be changed.

3.1.2 Oil Type and Quantity

See Section 1.5 - Oil Filling - for detail on oil type and quantity.

3.1.3 Oil and Filter Change

When using Busch R590 vacuum oil, it is recommended that oil changes are made every four (4) months or 750 hours of operation, whichever comes first (see 1.5 Oil Filling).

When using SAE motor oil, change every three (3) months or 500 hours of operation, shut the pump off, remove oil drain plug (Ref. 95), and drain the hot oil. Also at the same time replace the oil filter.

3.2 Automotive-Type Oil Filter

All R5 Series Single Stage Rotary Vacuum Pumps are equipped with an automotive-type oil filter (Ref. 100). Replace installed automotive-type oil filter with the following or equivalent type filter:

Model	Busch Part No.	Use in case of Emergency
0025-0040		Fram PH966B,
0063-0100	531.002.00	Mann W-712
0250	531.001.00	Fram PH16

3.3 Exhaust Filter (Pos. 120)

Every nine (9) to twelve (12) months or as necessary, replace the exhaust filter elements.

WARNING: If the gas entering this pump is a health hazard, use rubber gloves and all necessary personal protection equipment when performing the exhaust filter replacement operation.

WARNING: Wear safety glasses when installing or removing the spring retainers. The retainers can, if not secured correctly, slip off and fly out of the exhaust box.



Figure 4 Removing Exhaust Housing

3.3.1 Filter Replacement

Remove the four socket head cap screws (Ref. 155, 146) retaining the exhaust port housing. Pull the housing off the exhaust box and set it aside.

Use a slotted head screw driver to loosen the exhaust filter retaining spring, then rotate and remove the spring. Pull the filter cartridge (Ref. 120) out of the exhaust box.

To field test an exhaust filter element, remove it from the pump, allow it to cool, clean the sealing end (or O-ring end), use compressed air, regulated at 5 psig to blow through the element; 3 to 6 psig is the maximum allowable operating pressure across the filter. *Note: Use a shop rag to seal off the connection between the air hose and the filter.* If you can blow through it, the element is good. If not, discard it and replace the filter. The filter cannot be cleaned successfully. Visually inspect the filter element for cracks.

Reinstall the filter elements. Make sure the open end of the element is properly seated down in its recess in the exhaust box (see Figure 3) with the O-ring (Ref.121) correctly positioned. Retain the filter with the spring clip, tighten the tension screw until the filter is secure. Place the exhaust port gasket and housing in position on the exhaust box and retain with the cap screws.

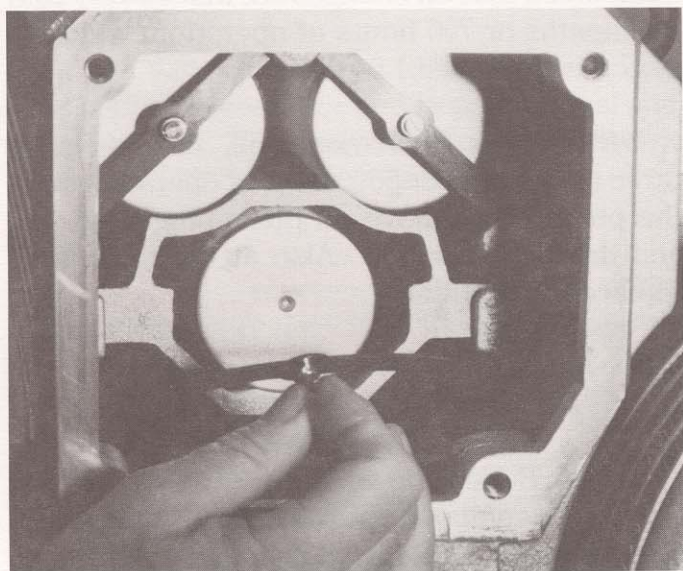
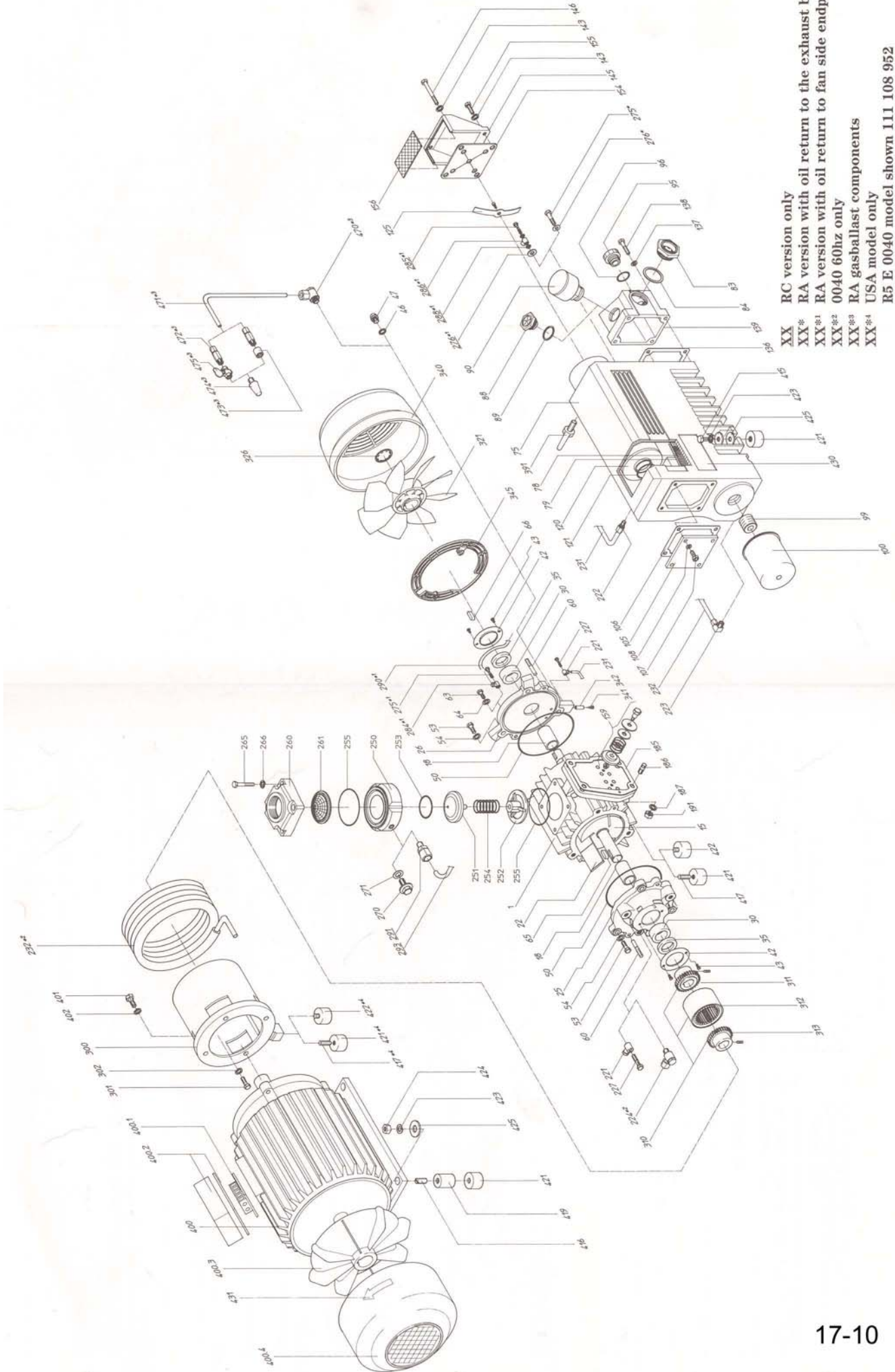

Figure 5 Removing Filter Spring

The service life of the exhaust filters varies widely with pump application. It is only necessary to change the filters when the elements become clogged with foreign material or burned oil. Indication of clogged filters are: exhaust pressure gauge reads close to the red zone, smoke and oil mist coming from the pump exhaust, higher than normal motor current, or oil leaking from the gas ballast valve on RA models.



RC version only
 XX
 XX* RA version with oil return to the exhaust box
 XX* RA version with oil return to fan side endplate
 XX** 0040 60hz only
 XX** RA gasballast components
 XX** USA model only
 R5 E 0040 model shown 111 108 952

0025 - 0250 "C" & "E" Parts List

Ref.	Description	Ref.	Description	Ref.	Description
1	Cylinder	150	Lockwasher	285	Screw, oil recirculation
5	Screw, socket Set	153	Baffle, exhaust	286	Banjo fitting housing
15	Rotor	154	Gasket, exhaust housing	288	Gasket ring
18	Bearing sleeve	155	Screw, exhaust housing	290	Oil return line, RA version
22	Vane	156	Screen, exhaust housing	291	Hyd. fitting, straight
25	Endplate, motor side	159	Valve assembly, exhaust	293	Oil return line, RC version
26	Endplate, fan side	161	Service block, oil	297	Fan guard screen
30	Bearing	162	Gasket, exh. service block	298	Screw, fl. head, slotted
31	Spacer, bearing to Seal	163	Screw, socket head cap	299	Washer, star
35	Shaft seal	164	Lockwasher	300	Motor mounting bracket
42	Retainer ring	165	Screw, socket head cap	301	Screw hex head cap
43	Screw, hex head	166	Lockwasher	302	Lockwasher
46	Plug, R 1/4"	168	O-ring	306	Adapter, motor flange
	Gasket-ring	169	Plate, valve cover/oil baffle	307	Screw, socket head cap
47	Plug	175	Screw, socket head cap	310	Coupling assembly
49	O-Ring	176	Lockwasher	311	Coupling half, pump side
50	O-ring	185	Gasket, cylinder/exhaust box	312	Coupling sleeve
53	Screw, hex head	186	Stud	313	Coupling half, motor side
54	Lockwasher	187	Lockwasher	319	Spacer, motor to coupling
57	Screw, socket head cap	189	Stud	320	Spacer
58	Lockwasher	190	Lockwasher	321	Fan, axial
60	Taper pin	191	Nut	322	Fan
63	Plug	205	Plate, valve access, exhaust box	325	Spacer
64	Gasket-ring	206	Gasket, cover plate	326	Retainer ring, fan
65	Shaft key	207	Screw, socket head cap	340	Fan guard
66	Shaft key	208	Lockwasher	341	Screw, sheet metal
75	Exhaust box	219	Hydraulic fitting	342	Sleeve, plastic
78	Baffle, expanded metal	220	Hydraulic fitting	345	Fan cover shield
79	Demister pad	221	Hydraulic fitting banjo	353	Screw, socket head cap
80	Baffle, sheet metal	222	Hydraulic fitting, straight	360	Lockwasher
83	Oil sight glass	223	Hydraulic fitting, elbow	390	Adapter, eye bolt
84	Gasket ring, sight glass	224	Hydraulic fitting, banjo	391	Bolt, eye
88	Oil fill plug	225	Hydraulic fitting, straight	392	Lockwasher
89	Gasket ring, fill plug	227	Screw, oil recirculation	393	Screw, hex head cap
90	Exhaust pressure gauge	230	Oil tubing	400	Motor
95	Oil drain plug	231	Oil tubing	401	Screw, hex head cap
96	O-ring	232	Oil cooling coil	402	Lockwasher
99	Pipe nipple		Oil tubing	409	Spacer, foot
100	Oil filter, spin-on type	233	Hydraulic banjo fitting	411	Washer, flat
105	Cover, exhaust box	236	Oil tubing	415	Screw, hex. head cap
106	Gasket, exhaust box cover	238	Screw, socket head cap	416	Stud, motor foot
107	Screw, exhaust box	239	Lockwasher	417	Set screw
108	Lockwasher	240	Oil cooling coil	419	Spacer, motor foot
115	Bracket, filter	241	Oil cooler	421	Foot, rubber
120	Exhaust filter	242	O-ring	422	Foot, rubber
121	O-ring	244	Fan cover	423	Lockwasher
125	Filter spring assembly	247	Screw, socket head cap	424	Hex nut
126	Screw, filter spring	250	Housing, lower, inlet	425	Stud
136	Gasket, exhaust box, service block	251	Valve plate, inlet	429	Rivet
137	Lockwasher	252	Valve plate guide	430	Name plate
138	Screw	253	O-ring	431	Label "arrow"
139	Service block	254	Spring, valve plate	436	Label, maintenance
140	Plate/housing, exhaust	255	O-ring	470	Hyd. fitting banjo
141	Gasket, exh. flange	260	Inlet flange, upper	471	Tubing, gas ballast
142	Screw, socket head cap	261	Inlet screen	472	Valve, check gas ballast
143	Lockwasher	265	Screw, hex head cap	473	Reducer, bell
144	Screw, socket head cap	266	Lockwasher	474	Filter, gas ballast
145	Housing, exhaust port	270	Plug	475	Valve, pet cock (optional)
146	Screw, exhaust housing	271	Gasket ring	476	Elbow, gas ballast
148	Baffle, oil, service block	275	Oil return valve	477	Valve, gas ballast
149	Screw, socket head cap	276	Gasket ring	478	Screw, hex. head cap
		284	Hydraulic, fitting banjo	479	Lockwasher

3.4 Vacuum Inlet Filter

If the pump is equipped with a special vacuum inlet filter in applications where powder, dust, or grit is present, the filter cartridge should be cleaned or exchanged on a weekly basis, depending on the amount of foreign particles to which the pump is exposed.

3.5 Maintenance Chart

Daily: Visually check oil level (see 3.1.1 and 3.1.2).

Weekly: Inspect inlet filter (see Section 3.4).

Every three (3) or four (4) months, 500 or 750 hours operation, or as necessary: See 3.1.3 and 1.5. Drain and discard oil from the hot pump. Replace the automotive-type oil filter and refill with fresh oil through the fill plug (see 3.1.2 through 3.1.3 and 3.2).

Every nine (9) to eighteen (18) months, or as necessary: Replace the exhaust filter elements (see 3.3).

3.6 Overhaul Kit/Filter

An overhaul kit containing a set of gaskets, O-rings, vanes, bearings, bearing sleeves, shaft seals, and taper pins is available from the factory.

Also, a filter kit containing oil drain plug, gaskets, automotive-type oil filter, (where applicable) and exhaust filter, is available from the factory.

When ordering, please specify pump size and model (a 3-digit suffix after size), and serial number.

4.0 TROUBLESHOOTING

4.1 Trouble

Pump does not reach "blank-off" pressure which is the lowest absolute pressure (best vacuum) when running with the inlet closed via a blank flange or a valve; or pump takes too long

to evacuate the system. The "blank-off" pressure can be measured by using a good quality capsule gauge.

4.1.1. Possible Cause

Contaminated oil is by far the most common cause of not reaching the ultimate pressure.

Remedy:

Shut off the pump, after operating temperature has been reached, drain the warm oil from the pump and exchange automotive-type oil filter (where applicable), if necessary. Fill with new oil and take a new "blank-off" measurement after operating temperature is reached (at least 20-30 minutes).

4.1.2 Possible Cause

Vacuum system or vacuum piping not leak-tight.

Remedy:

Check hose and pipe connections for possible leak.

4.1.3 Possible Cause

Wire mesh inlet screen plugged (Ref. 261).

Remedy:

Clean wire mesh inlet screen. Install inlet filter if problem repeats frequently.

4.1.4 Possible Cause

No oil or not enough oil in oil reservoir.

Remedy:

Shut off the pump, drain balance of oil from the pump, exchange automotive oil filter, and refill with fresh oil.

4.1.5 Possible Cause

Automotive-type oil filter is dirty or clogged (where applicable).

Remedy:

Replace automotive-type oil filter, exchange oil, if necessary, and refill with fresh oil.

4.1.6 Possible Cause

Inlet valve plate (Ref. 251) stuck in closed or partially open position due to contamination.

Remedy:

Disassemble inlet valve and screen. Clean as required.

4.1.7 Possible Cause

Oil tubing defect and/or leaking. Oil return line broken on RC model.

Remedy:

Replace or retighten oil fittings or oil tubing. Replace only with same size tubing.

4.1.8 Possible Cause

Shaft seal leaking.

Remedy:

Replace the shaft seal following disassembly and assembly steps outlined in the Maintenance and Repair Manual. Check the shaft seal. It should have a spring installed inside and around the shaft sealing lip.

4.1.9 Possible Cause

Exhaust valve (Ref.159) not properly seated or partially stuck open.

Remedy:

Follow disassembly and assembly steps outlined in the Maintenance and Repair Manual.

4.1.10 Possible Cause

Vanes blocked in rotor or otherwise damaged.

Remedy:

Free vanes or replace with new ones following disassembly and assembly steps outlined in the Maintenance and Repair Manual.

4.1.11 Possible Cause

Radial clearance between rotor and cylinder no longer adequate.

Remedy:

Follow disassembly and assembly steps outlined in the Maintenance and Repair Manual on resetting radial clearance correctly.

4.1.12 Possible Cause

Internal parts worn or damaged.

Remedy:

Follow disassembly and assembly steps outlined in the Maintenance and Repair Manual and replace worn or damaged parts.

4.1.13 Possible Cause on RC Models Only

The oil return line (Ref. 290) is connected directly to atmospheric pressure in the exhaust area. On small model pumps, a fairly large amount of air is sucked through the oil return line, and it may not be possible to reach 15 torr or 29.4 inches Hg. blank-off on the inlet of the pump under these conditions.

Blank-off of 29.4 inches Hg or 15 torr can be reached by temporarily disconnecting and closing the oil return line; also by squirting oil through the exhaust opening into the exhaust filter area. The oil will be sucked into the oil return line, and no air will reach the inlet, thus affecting the "blank-off" pressure.

4.2 Trouble

Pump will not start.

4.2.1 Possible Cause

Motor does not have proper supply voltage or is overloaded; motor starter overload settings are too low or wrong setting; fuses are burned; or wire is too small or too long, causing a voltage drop at the pump.

Remedy:

Check correct supply voltage; check overload settings in motor starter for size and setting according to motor nameplate data; check fuses; and install proper size wire. If ambient temperature is high, use larger size overloads or adjust setting 5% above nominal motor nameplate value.

4.2.2 Possible Cause

Pump or motor is blocked.

Remedy:

Remove fan cover and try to turn pump and motor by hand. If frozen, remove motor from pump and check motor and pump separately. If pump is frozen, disassemble completely per the Maintenance and Repair Manual and remove foreign objects in the pump or replace broken vanes.

4.3 Trouble

Pump starts, but labors and draws a very high current.

4.3.1 Possible Cause

Oil too heavy (viscosity too high) or ambient temperature below 5 degrees C (41 degrees F).

Remedy:

Change to a 10W40 multi-purpose motor oil - only use when necessary since continued use may clog filter elements prematurely.

4.3.2 Possible Cause

Pump runs in the wrong direction.

Remedy:

Check for correct rotation which is counter-clockwise when looking at the motor from the motor's fan side.

4.3.3 Possible Cause

Pump is overfilled with oil or the wrong kind of oil is used.

Remedy:

Correct the oil level and quality per Section 1.5 and use recommended motor oil.

4.3.4 Possible Cause

Exhaust filters in exhaust chamber are clogged and appear burned black with pump oil.

Remedy:

Replace exhaust filters, maintain proper oil condition, oil level, and use recommended non-detergent motor oil.

4.3.5 Possible Cause

Exhaust filter is clogged due to process material.

Remedy:

Contact factory for recommendation or proper filter cartridge.

4.3.6 Possible Cause

Loose connection in motor terminal box; not all motor coils are properly connected. Motor operates on two phases only.

Remedy:

Check motor wiring diagram for proper hook-up, especially on motors with six internal motor windings, tighten and/or replace loose connections.

4.3.7 Possible Cause

Foreign particle in pump, vanes broken, bearing seizing.

Remedy:

Follow disassembly and assembly steps outlined in the Maintenance and Repair Manual and remove foreign parts, and replace vanes and bearings.

4.4 Trouble

Pump smokes at the exhaust side or expels oil droplets from the exhaust.

4.4.1 Possible Cause

Exhaust filter not properly seated with O-ring (Ref. 121) in filter base or filter material cracked.

Remedy:

Check condition and placement of exhaust filters in filter base. Replace if necessary.

4.4.2 Possible Cause

Exhaust filter clogged with foreign particles.

Remedy:

Replace exhaust filter. Install other factory recommended filter cartridges if pump application requires other filter cartridges.

4.4.3 Possible Cause

Oil recirculation valve (Ref. 275) not properly working or clogged. Proper function is that when blowing into check valve, it should close. When sucking on it, check valve should open.

WARNING: Do not inhale through or allow your mouth to come in direct contact with the oil recirculation valve.

Remedy:

Free or replace oil recirculation check valve.

4.4.4 Possible Cause

If RA Series vacuum pumps run continuously over 10 hours without ever being shut down, it may be possible that oil accumulates behind the exhaust box cover to the extent that oil is blown out of the exhaust with the exhaust gas.

Remedy:

Shut pump down during break periods or install additional oil return line assembly. Check that oil recirculation valve (Ref. 275) is free and drains oil back into pump when RA Series pump is stopped.

4.4.5 Possible Cause

Oil return line (Ref. 290) on RC Standard pumps clogged or broken.

Remedy:

Free clogged line, replace broken line, but only with proper size, and check that oil is pumped out of oil sump while vacuum pump is operating.

NOTE: An oil filling plug with pressure gauge is provided on all R5 Series pumps, so that the pressure in front of the exhaust filters can be monitored. The green field (0 through 0.6 bar) is between 0 and 9 psi and indicates that the filters are still effective. Any back pressure close to 9 psi requires immediate change of the exhaust filter (Ref. 120).

4.5 Trouble

Pump runs very noisy.

4.5.1 Possible Cause

Coupling insert worn.

Remedy:

Replace coupling insert in motor/pump coupling.

4.5.2 Possible Cause

Bearing noise.

Remedy:

Follow disassembly and assembly steps outlined in the Maintenance and Repair Manual and replace bearings.

4.5.3 Possible Cause

Vanes stuck.

Remedy:

Follow disassembly and assembly steps outlined in the Maintenance and Repair Manual and replace vanes. Use only recommended motor oil and change oil more frequently.

4.6 Trouble

Pump runs very hot. See Technical Data for typical oil sump temperature.

4.6.1 Possible Cause

Not enough air ventilation to the pump.

Remedy:

Clean motor and pump air grills. Do not install the pump in an enclosed cabinet unless a sufficient amount of fresh air is supplied to the pump. On pumps with oil cooling coils, clean outside fin assembly. Consult Busch Engineering for recommendation.

4.6.2 Possible Cause

Automotive-type oil filter clogged and pump does not receive enough oil.

Remedy:

Change automotive oil filter.

4.6.3 Possible Cause

Not enough oil in oil reservoir or badly burned oil is used for pump lubrication.

Remedy:

Drain and refill only with non-detergent oil, increase oil change intervals.

NOTE: On some high temperature applications, it may be necessary to change to a high temperature oil. Contact the factory for recommendations.

4.7 Trouble

Pump is seized.

4.7.1 Possible Cause

Pump operated without oil and vanes broke.

Remedy:

Disassemble and exchange vanes as outlined in the Maintenance and Repair Manual.

4.7.2 Possible Cause

Pump was operated for an extended period of time in the wrong rotation.

Remedy:

Inspect vanes and replace.

4.7.3 Possible Cause

Liquid carryover into the pump cylinder broke vanes while pump was running, or oil broke vanes on start-up.

Remedy:

(a) Install condensate trap on the inlet of the pump.

(b) Pump was overfilled with oil in oil reservoir. Follow oil filling procedure (see Section 1.5) and do not overfill.

(c) Built-in anti-suck-back valve (Ref. 250 through 255) leaking while pump was shut down and vacuum was left in manifold. Clean valve seat and check that anti-suck-back valve holds vacuum on inlet when pump is shut down.

(d) Two pumps or a receiver is on the same main line. Install a manual or automatic operated valve in front of each pump.

4.8 Trouble

Automotive-type oil filter (Ref. 100) does not get warm within two to five minutes when cold pump is started.

4.8.1 Possible Cause

Automotive-type oil filter is clogged.

Remedy:

Replace automotive-type filter per Section 3.2 and exchange oil per Section 1.5.

4.8.2 Possible Cause

Wrong automotive-type filter is used and/or oil lines leading to pump are clogged.

Remedy:

Use only automotive filter as listed in Section 3.2 and blow lines free.

5.0 LIMITED STANDARD AND EXTENDED WARRANTY

Busch, Inc. warrants that all products furnished by it are free from defects in material and workmanship at the time of shipment for a period of eighteen months from the date of shipment, or one year from the date of installation, whichever occurs first. However, all R5 Series vacuum pumps that are ordered with the initial oil charge, operated from initial start-up through the full warranty period with the Busch R-500 Series oils, and have oil changes as recommended in the Operating and Installation Manual and Maintenance and Repair Manual, will receive a warranty extension of an additional six months. This means that the warranty will be effective for a period of eighteen months from date of start-up, or two years from date of shipment, whichever occurs first. Claims must be made during that period and are limited to the replacement or repair of parts claimed to be defective.

In the case of components purchased by Busch, Inc., such as starters, controls, mechanical seals, motors, couplings, etc., the warranty of that manufacturer will be extended to the purchaser in lieu of any warranty by us. The replacement of maintenance items including but not limited to packings, oil seals, bearings, coils, etc. made in connection with normal maintenance service are not covered by this Warranty.

The Limited Extended Warranty is valid only when the product has been properly installed, used in a normal manner, and serviced according to the operating manual. This Warranty shall not extend to products that have been misused, neglected, altered or repaired without factory authorization during the warranty period. Operating conditions beyond our control such as improper voltage or water pressure, excessive ambient temperatures, or other conditions that would affect the performance or life of the product will also cause the Warranty to become void.

Permission to return parts for warranty repair must be obtained, and all returns must be prepaid to the factory. If, after examination, the product or part is found to be defective, it will be repaired or replaced on a no-charge basis and returned, FOB the factory. On the other hand, if it is determined that the Warranty has not been breached by Busch, Inc., then the usual charges for repair or replacement will be made, FOB the factory. Parts or products that are obsolete or those made to special order are not returnable.

This Limited Warranty applies only to the above and is for the period set forth. Busch, Inc.'s maximum liability shall not, in any case, exceed the contract price for the product, part, or component claimed to be defective; and Busch, Inc. assumes no liability at all for any special, indirect, or consequential damages arising from defective equipment.

THERE ARE NO WARRANTIES IMPLIED OR EXPRESSED THAT EXTEND BEYOND THOSE CONTAINED IN THIS LIMITED WARRANTY.

TECHNICAL DATA "C" and "E" SERIES

	Type	0040
Theoretical Displacement	CFM	28
Typical oil sump temperature*		195°F
Guaranteed Vacuum without gas ballast - RA models	Torr	.5
RC models (standard)	Torr	15
Maximum sound level one meter from pump	dBA	70
Motor size - 3 phase	HP	2
Motor size - 1 phase	HP	2
Pump motor speed	RPM	1730
Oil capacity	Quart	1.6
Inlet connection	NPT	1 1/4"
Pump weight	lbs.	120
Shipping weight (approximate)	lbs.	161

MOTOR AND ELECTRICAL DATA "C"/"E" SERIES

PUMP TYPE		0040
Motor 60Hz 3 Phase	US Mfg. HP Motor Frame Rpm Volt Full load Amperage	2 145TC 1730 208/230/460 6.3/6.0/3.0
Starter	Teleme- Amp canique Size MSP	4-6.3/2.5-4
Motor 60 Hz 1 Phase	US Mfg. HP Motor Frame Rpm Volt Full load Amperage	2 145TC 1730 115/200/230 24/12.7/12

* Maximum oil temperature with 80°F ambient temperature and no supplemental oil cooling.

(Main Clutch)

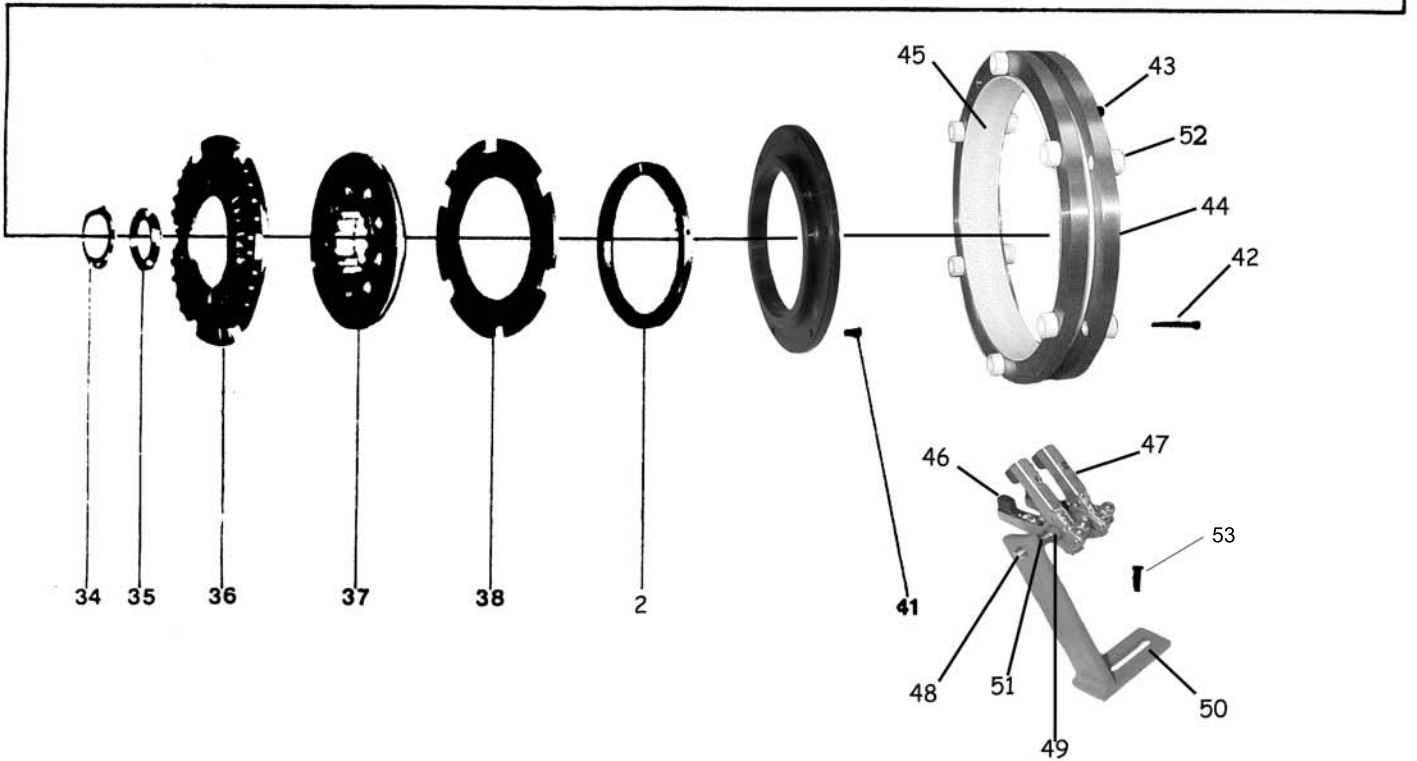
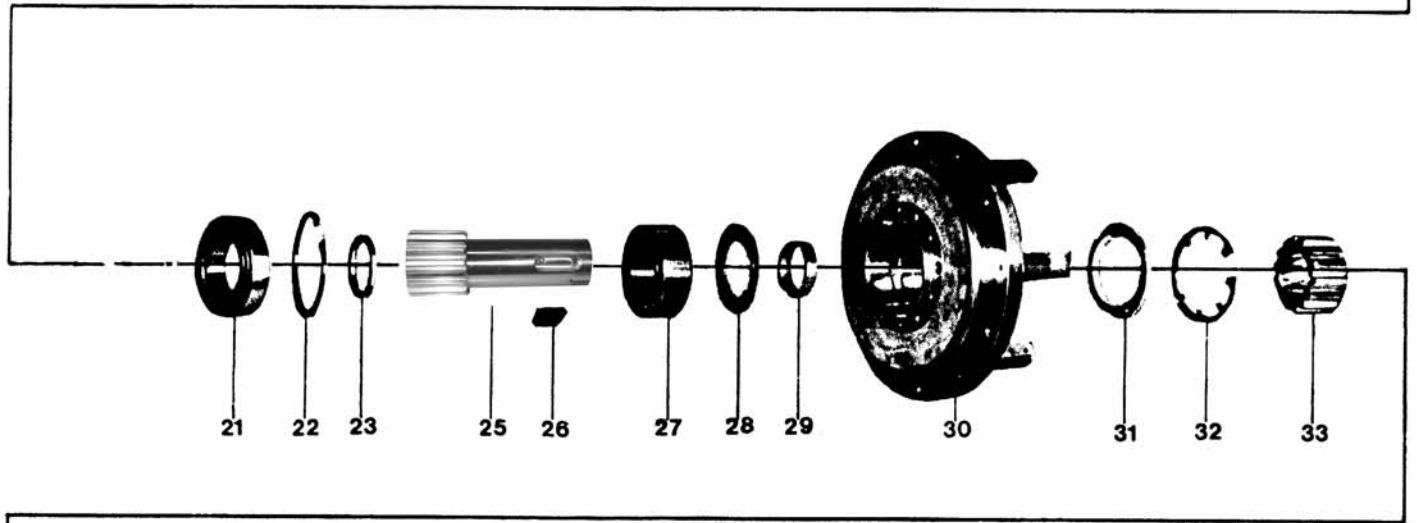
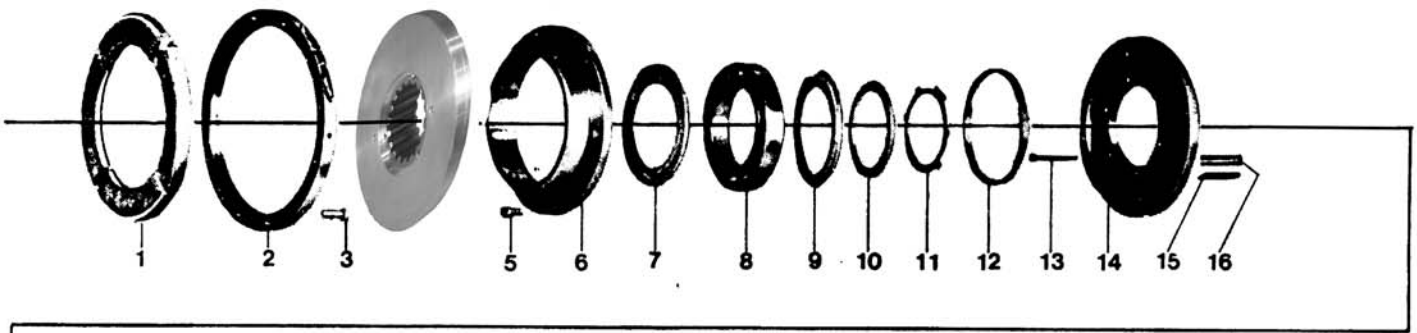

Henry & Sons Incorporated

Model-AC-20/30

(Main Clutch-1)

Pict. #	Part #	Quant	Description
1	091-090-506	1	Brake Plate
2	091-090-510	2	Adjusting Ring
3	040-205-110	8	Hex Head Bolt 5 X 20
4	091-090-540	1	Adjusting Ring Holder
5	040-205-095	6	Hex Head Bolt 5 X 16
6	091-090-514	1	Flange
7	062-960-172	1	Nilos Ring
8	063-060-173	1	Bearing 6017 2RS
9	062-960-172	1	Nilos Ring
10	091-090-521	1	Nilos Spacer
11	091-090-522	1	Seeger Locking Ring
12	555-007-025	1	Spacer
13	091-090-543	6	Hollow Head Bolt 5 X 70
14	091-090-524	1	Anchor Plate
15	091-090-505	6	Spring
16	091-090-513	6	Bushing
21	063-062-094	1	Bearing 6209 2RS
22	049-320-850	1	Snap Ring 85 X 3
23	091-090-528	1	Spacer (Thin)
25	091-090-539	1	Shaft With Spline
26	091-090-525	1	Key 14 X 10 X 27
27	063-332-091	1	Bearing 5209
28	091-090-529	1	Nilos Ring
29	091-090-527	1	Spacer (Thick)
30	091-090-512	1	Main Coil
31	091-090-530	1	Nilos Ring

Henry & Sons Incorporated

Model-AC-20/30 (Main Clutch-2)

Pict. #	Part #	Quant	Description
32	091-090-531	1	Seeger Locking Ring
33	091-090-511	1	Driver
34	091-090-532	1	Lockwasher
35	091-090-533	1	Slotted Nut
36	091-090-501	1	Pressure Disc
37	091-090-504	1	Clutch Disc
38	091-090-502	1	Friction Plate
39			
40	091-090-509	1	Adjusting Ring Holder
41	040-906-060	6	Hollow Head Bolt 6 X 12
42	040-905-252	6	Hollow Head Bolt 5 X 60
43	040-904-062	2	Hollow Head Bolt 4 X 12
44	555-007-001	2	Slip Ring
45	555-007-002	1	Insulating Ring
46	091-011-005	4	Carbon Brush
47	091-011-004	2	Brush Holder
48	110-620-190	1	Holder Pin
49	015-501-061	1	Insulating Tube
50	114-071-000	1	Brush Holder Bracket
51	045-008-060	1	Hex Nut 8mm
52	555-007-003	12	Insulator Bushings
53	040-906-115	2	Hollow Head Bolt 6 X 20
54			

HENRY & SONS INCORPORATED

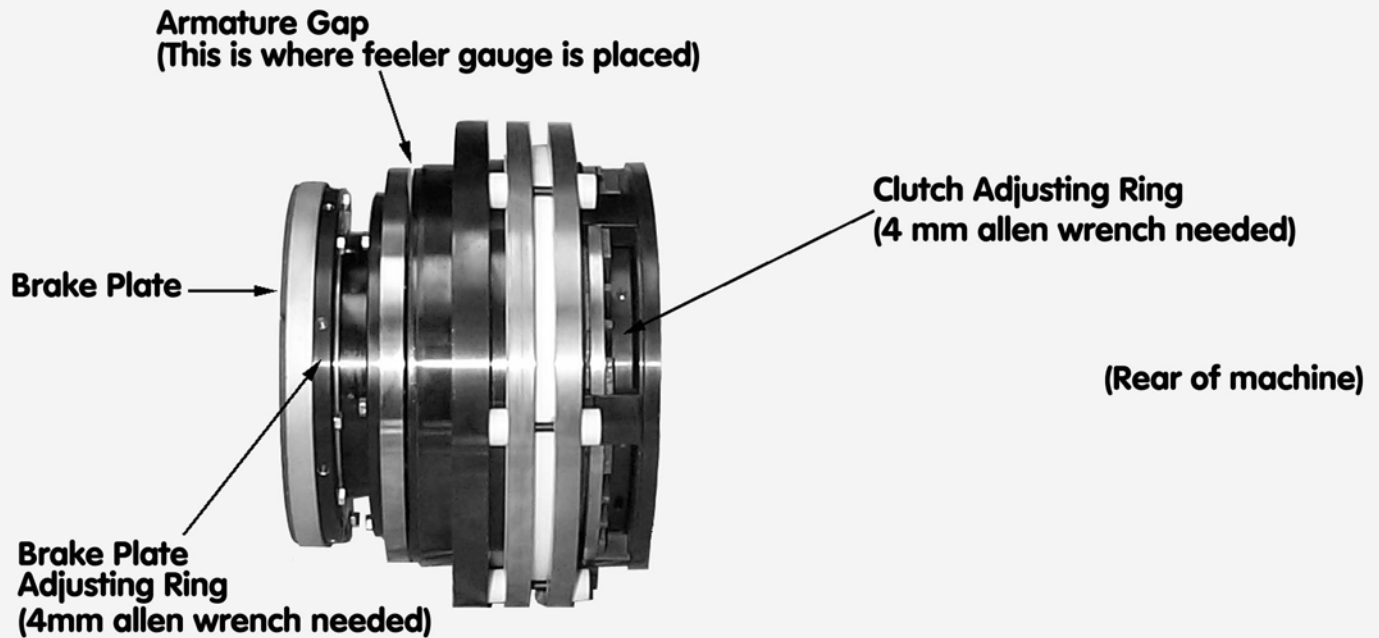

(THIS VIEW IS FROM OPERATOR SIDE OF MACHINE)

DIRECTIONS FOR ADJUSTING MAIN CLUTCH

1. Open rear hood
2. Turn on main power , do not push start button ,trigger saftey switch if nessary to prevent motor from starting.
3. With clutch de-energized Loosen bolt on clutch adj. ring and screw twards back of machine as far as it will go.
4. (Adjust brake) With clutch de-energized a 1.2mm feeler gauge should fit snug in armature gap. If adjustment is needed (energize clutch) loosen bolt on brake plate adj. ring and adjust. Re-check armature gap. Tighten bolt.
5. (Adjust clutch) with clutch de-energized place 0.8 feeler gauge in armature gap (energize clutch) when the armature gap closes it should loosely(as if you where to hold feeler gauge with your thumb and index finger) grab the feeler gauge. If adjustment is needed adjust with clutch de-energized. Loosen bolt on clutch adj. ring , adjust. Re-check armature gap. Tighten bolt when finished.

AC-20/30 Main Electrical Panel and Door

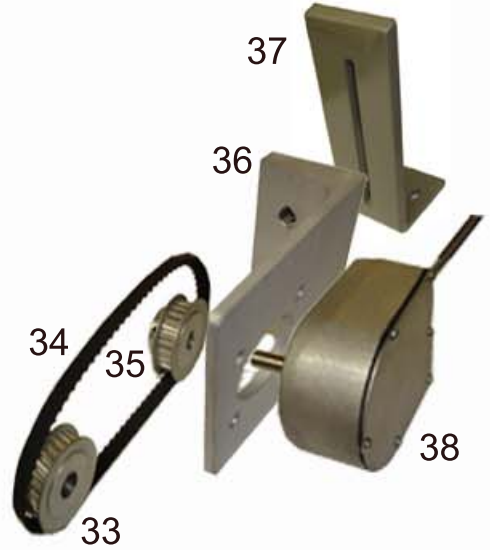
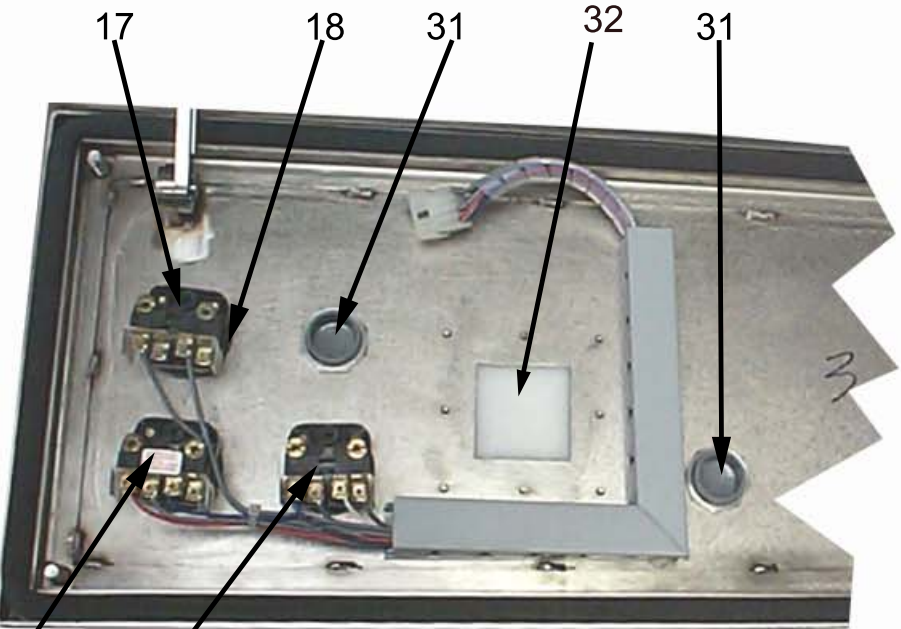
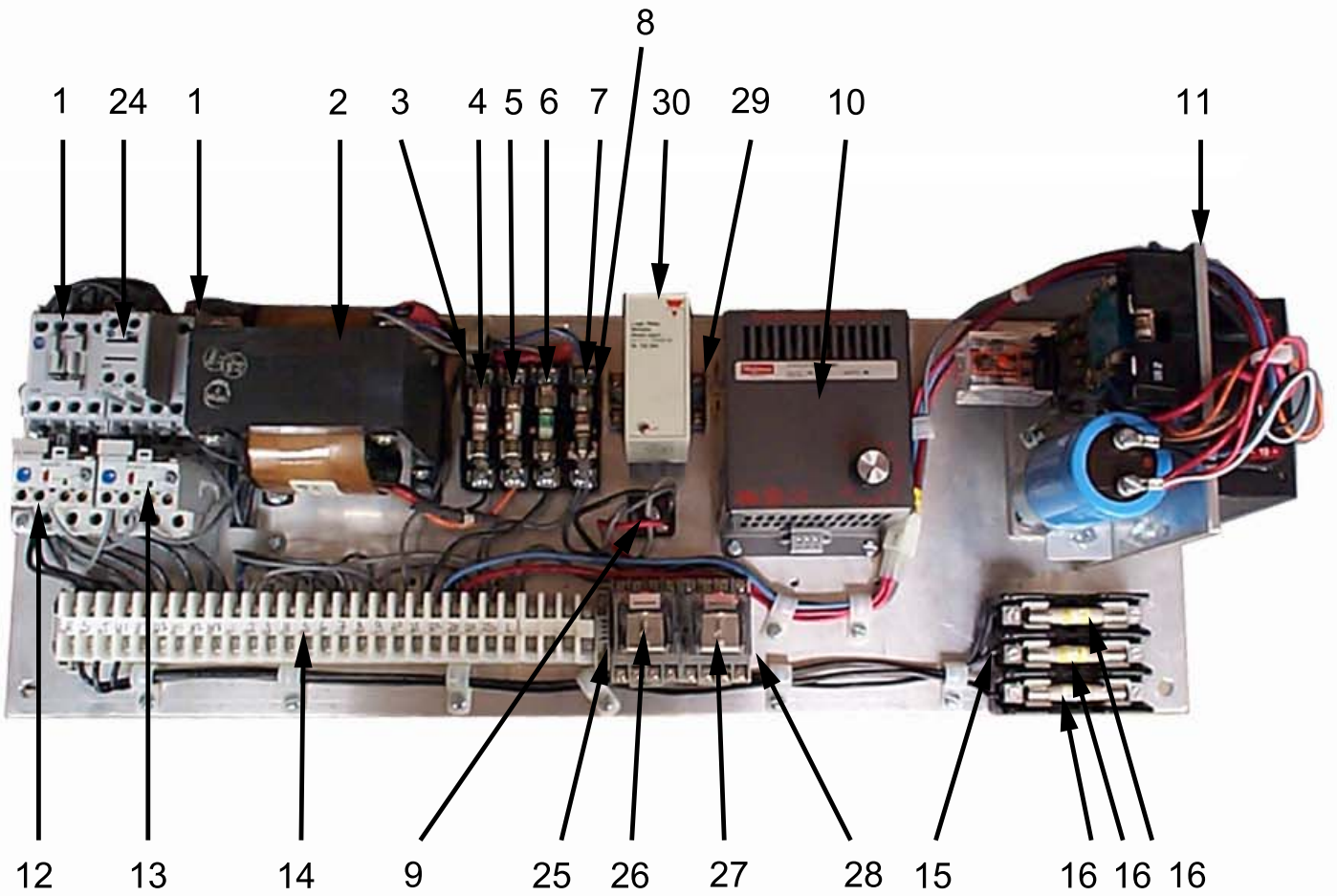

20-1

Henry & Sons Incorporated

Model-AC-20/30(Elect panel / Door-1)

Pict. #	Part #	Quant	Description
1	555-013-040	2	IEC Contactor
2	555-013-018	1	Transformer 220-110/440
3	555-013-051	1	3 Fuse ,Fuse Holder
4	555-013-061E	1	5 Amp Fuse, KTK-5
5	555-013-061E	1	5 Amp Fuse,KTK-5
6	555-013-061B	1	3 Amp Fuse, FNQ-R-3
7	555-013-061I	1	10 Amp Fuse, KTK-R-10
8	555-013-050	1	1 Fuse ,Fuse Holder
9	555-013-009	1	Rectifier
10	555-013-030	1	Heater
11	555-013-012	1	Power Supply
12	555-013-041	1	Overload
13	555-013-042	1	Overload
14	555-013-039	1	Terminal Strip
15	555-013-049	1	3 Fuse, Fuse Holder
16	555-013-056	3	45 Amp Fuse (SC-45) (50 AMP 30 HP)
17	555-013-057	3	Push Button
18	555-013-055A	1	Push Button Contacts N/O
19	555-013-055	1	Push Button Contacts 2 - N/O
20	555-013-054	1	Push Button Contacts 2 - N/C
21	555-013-059	1	2 Position Switch/used with portioner opt. only
22	555-013-021	1	Digital Portioner
23	555-013-027	1	5000 Ohm Pot
24	555-013-043	1	Auxiliary Contacts

Henry & Sons Incorporated

Model-AC-20/30(Elect panel / Door-2)

Pict. #	Part #	Quant	Description
25	555-013-068	1	8 Pin Socket
26	555-013-067	1	Hopper Safety Relay
27	555-013-068	1	8 Pin Socket/Used with Portioner Opt. Only
28	555-013-067	1	Portioner Relay/Used with Portioner Opt. Only
29	555-013-047	1	11 Pin Socket/Used with Portioner Opt. Only
30	555-013-028	1	Logic Relay/Used with Portioner Opt. Only
31	555-013-057c	1	Plug
32	555-013-020c	1	Portioner Plug Cover
33	555-013-023a	1	Pulley 12mm bore
34	555-013-023b	1	Portioner Belt
35	555-013-023	1	Encoder Pulley
36	555-013-025	1	Encoder Bracket
37	555-013-025a	1	Encoder Base Bracket
38	555-01-022	1	Encoder

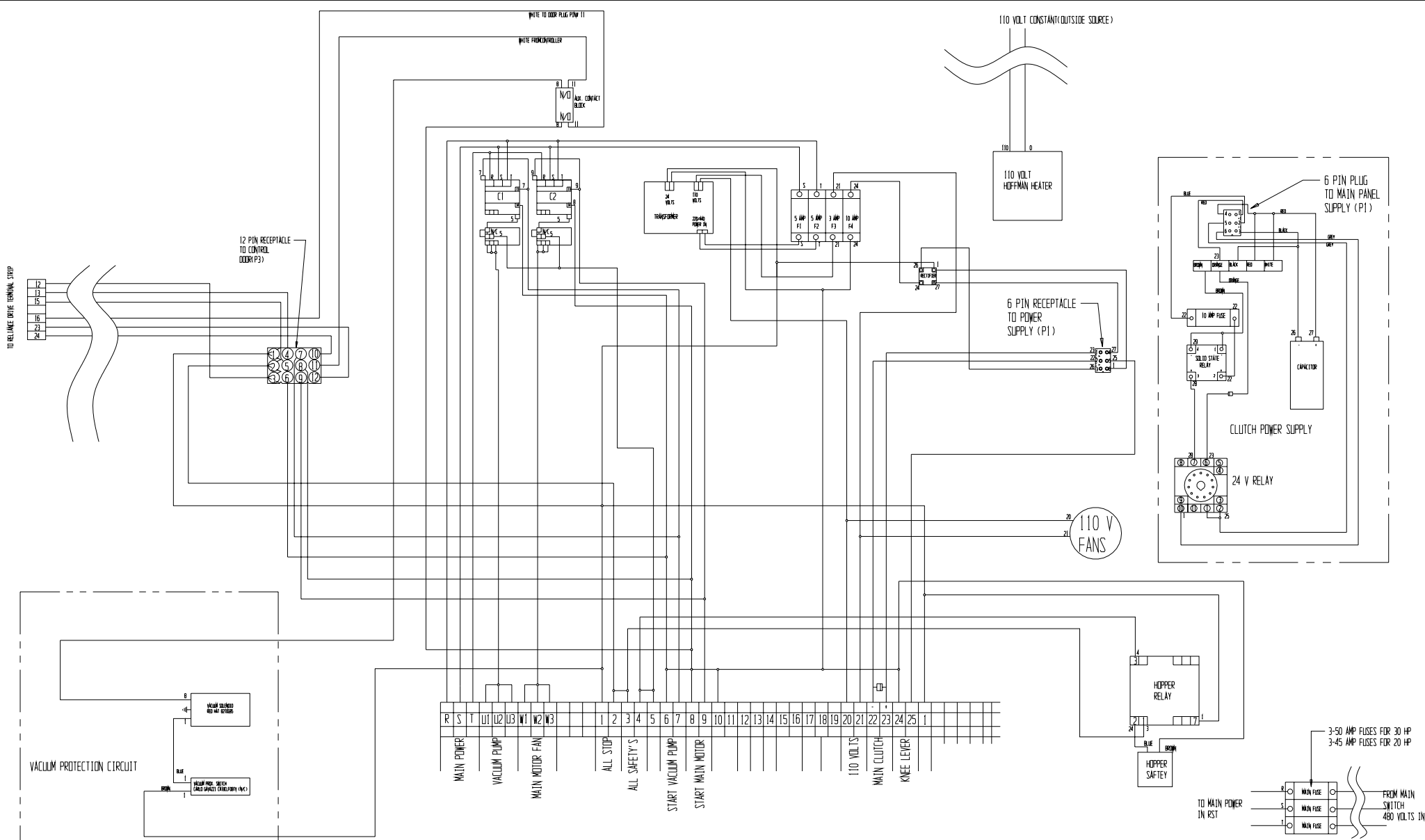

H1			
H2	REMOVE THERMAL OVERLOAD FOR VAC PUMP (RESCALE THERM PUMP)		11-2-04
H3			
H4			
Revision	Revision Description	Approved	Date

HENRY & SONS, INC.
 58480 Frudden Rd., Brodley, Calif. 93426
 800-752-7507

THIS DRAWING CONTAINS PROPRIETARY INFORMATION AND SHALL NOT BE COPIED, DISTRIBUTED, DISCLOSED, OR USED WITHOUT WRITTEN PERMISSION FROM HENRY & SONS, INC.

CUSTOMER:		Title	AC-20/30 MASTER MAIN ELECTRICAL PANEL PRINT	
MACHINE MODEL:		Drawn	MARK HENRY	Date 7/3/03
BUILD DATE:		Checked		Date
		Approved		Date
		Directory	CAD File No.	Drawing No.
		Scale:	FULL	Size: Sheet 1
				Rev. H2

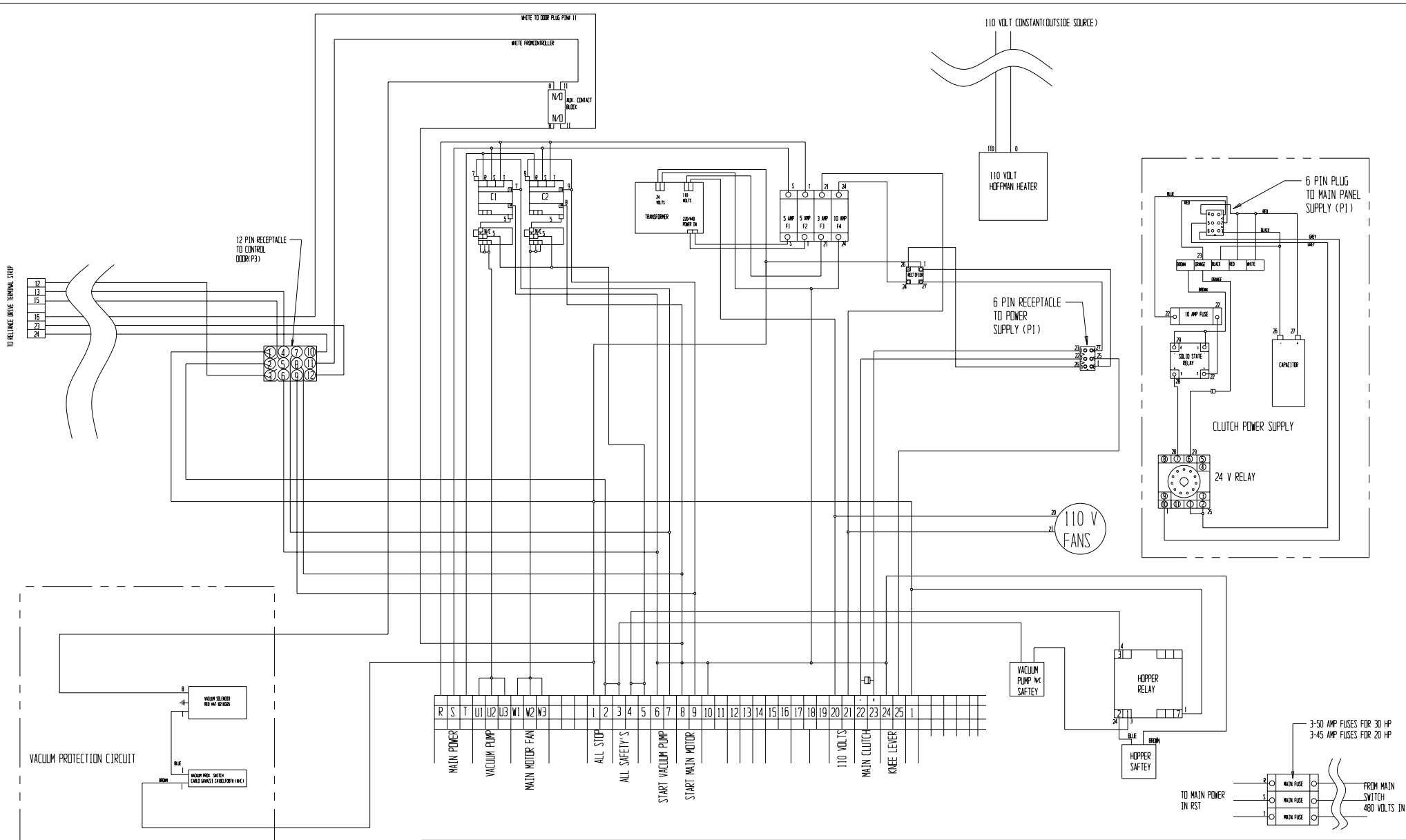

H1	RELEASE (FOR BUSH VAC. PUMP W/SAFETY)	WH	7/3/03
H2			
H3			
H4			
H5			
Revision	Revision Description	Approved	Date

HENRY & SONS, INC.
 58480 Prudden Rd., Bradley, Calif. 93426
 800-752-7507

THIS DRAWING CONTAINS PROPRIETARY INFORMATION AND SHALL NOT BE COPIED, DISTRIBUTED, DISCLOSED, OR USED WITHOUT WRITTEN PERMISSION FROM HENRY & SONS, INC.

CUSTOMER: _____
 MACHINE MODEL: _____
 BUILD DATE: _____

Drawn: MARK HENRY Date: 7/3/03
 Checked: _____ Date: _____
 Approved: _____ Date: _____

Title: **AC-20/30 MASTER MAIN ELECTRICAL PANEL PRINT**

Directory/CAD File No. _____ Drawing No. _____ Rev: H1
 E./ PRT AC-MASTER MAIN BLEO
 Scale: FULL Size: Sheet 1

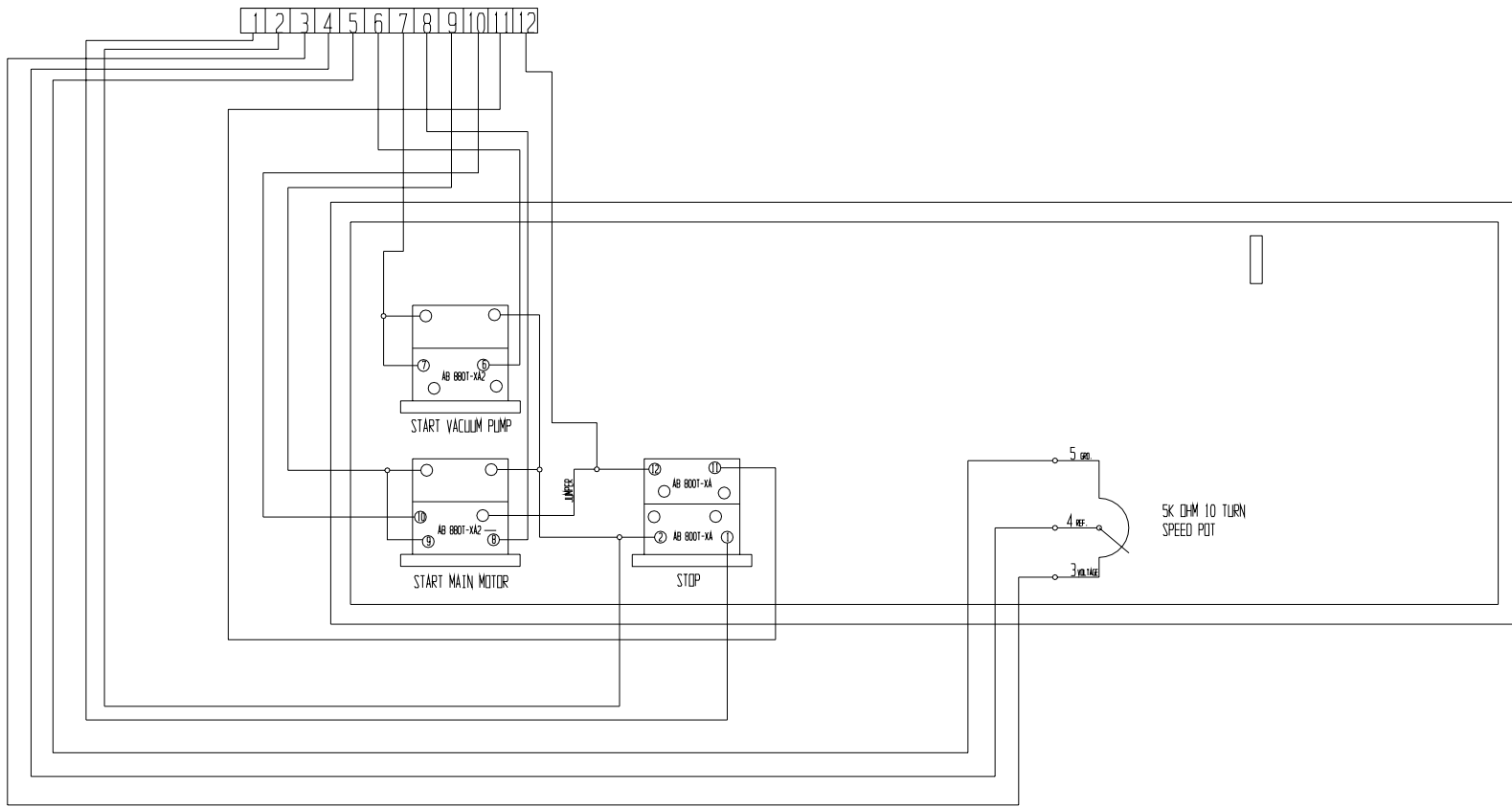
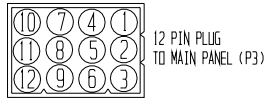

A			
B			
C			
D			
E			
Revision	Revision Description	Approved	Date

HENRY & SONS, INC.
58480 Frudden Rd. Bradley, Calif. 93426

THIS DRAWING CONTAINS PROPRIETARY INFORMATION AND SHALL NOT BE COPIED, DISTRIBUTED, DISCLOSED, OR USED WITHOUT WRITTEN PERMISSION FROM HENRY & SONS, INC.

CUSTOMER:	
MACHINE MODEL:	
BUILD DATE:	
Drawn	MARK HENRY
Checked	
Approved	
Date	7/8/03

Title	AC-20/30 MASTER (DOOR) PRINT		
Directory	CAD File No.	Drawing No.	Rev
C: PRT	AL-MASTER ELEC1.DR		H1
Scale: FULL	Size:	Sheet	21-3

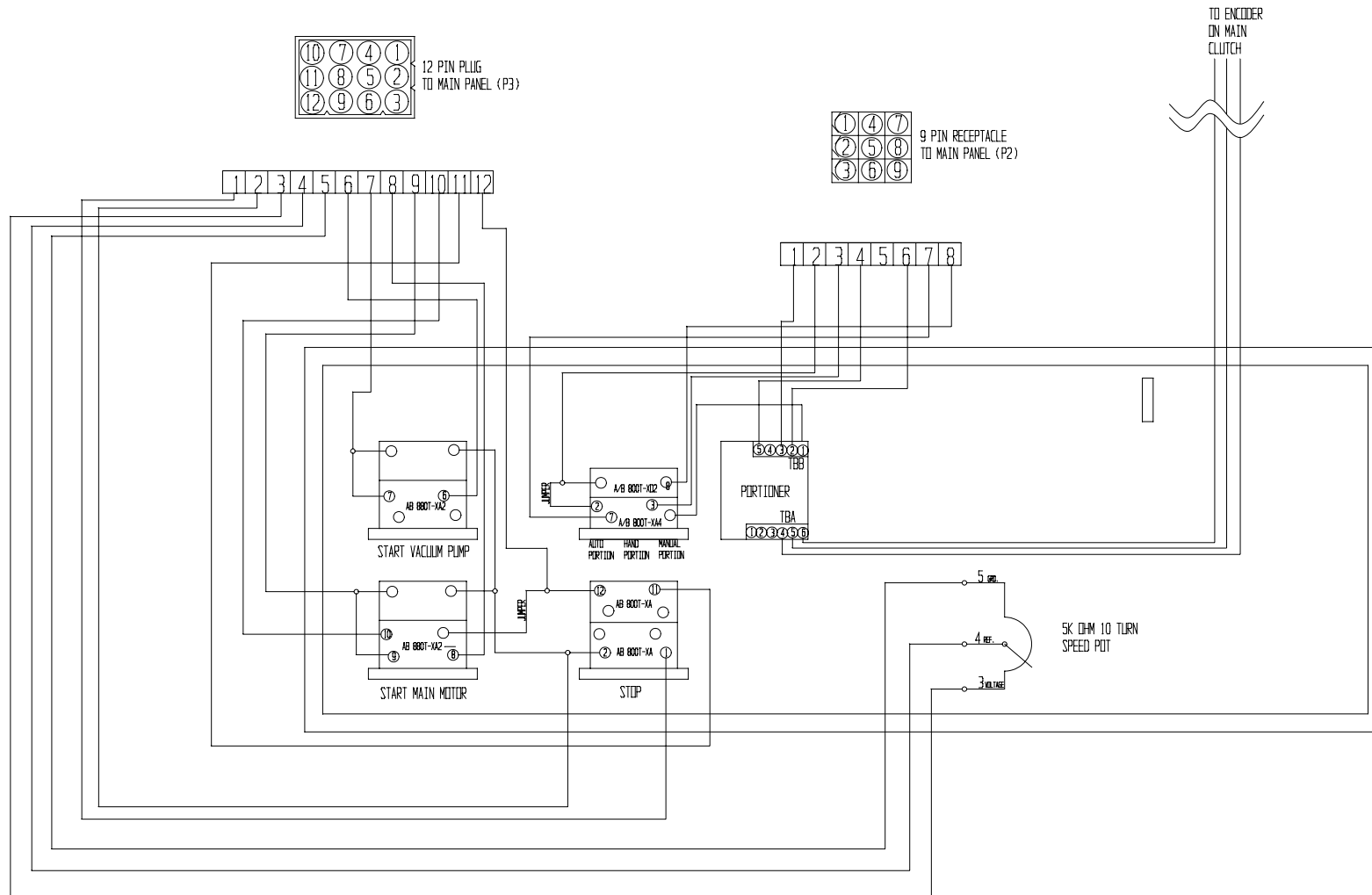

HI	INITIAL RELEASE		7-9-03
H2	1 & 3 INPUT ON PORTIONER		3-25-04
H3	PORTIONER WIRING CHANGES 1-5		4-27-04
Revision	Revision Description	Approved	Date

HENRY & SONS, INC.
58480 Frudden Rd. Bradley, Calif. 93426

CUSTOMER:	
MACHINE MODEL:	
BUILD DATE:	
Drawn	MARK HENRY
Checked	
Approved	
Date	7/8/03

Title		AC-20/30 PORTIONER OPTION (DOOR) PRINT	
Directory	CAD File No.	Drawing No.	Rev
C: PRT	AC-PORTIONER.DPT		H3
Scale:	FULL	Size:	Sheet 2

THIS DRAWING CONTAINS PROPRIETARY INFORMATION AND SHALL NOT BE REPRODUCED, COPIED, DISTRIBUTED, DISCLOSED, OR USED WITHOUT WRITTEN PERMISSION FROM HENRY & SONS, INC.

5 | 4 | 3 | 2 | 1

D
C
B
A

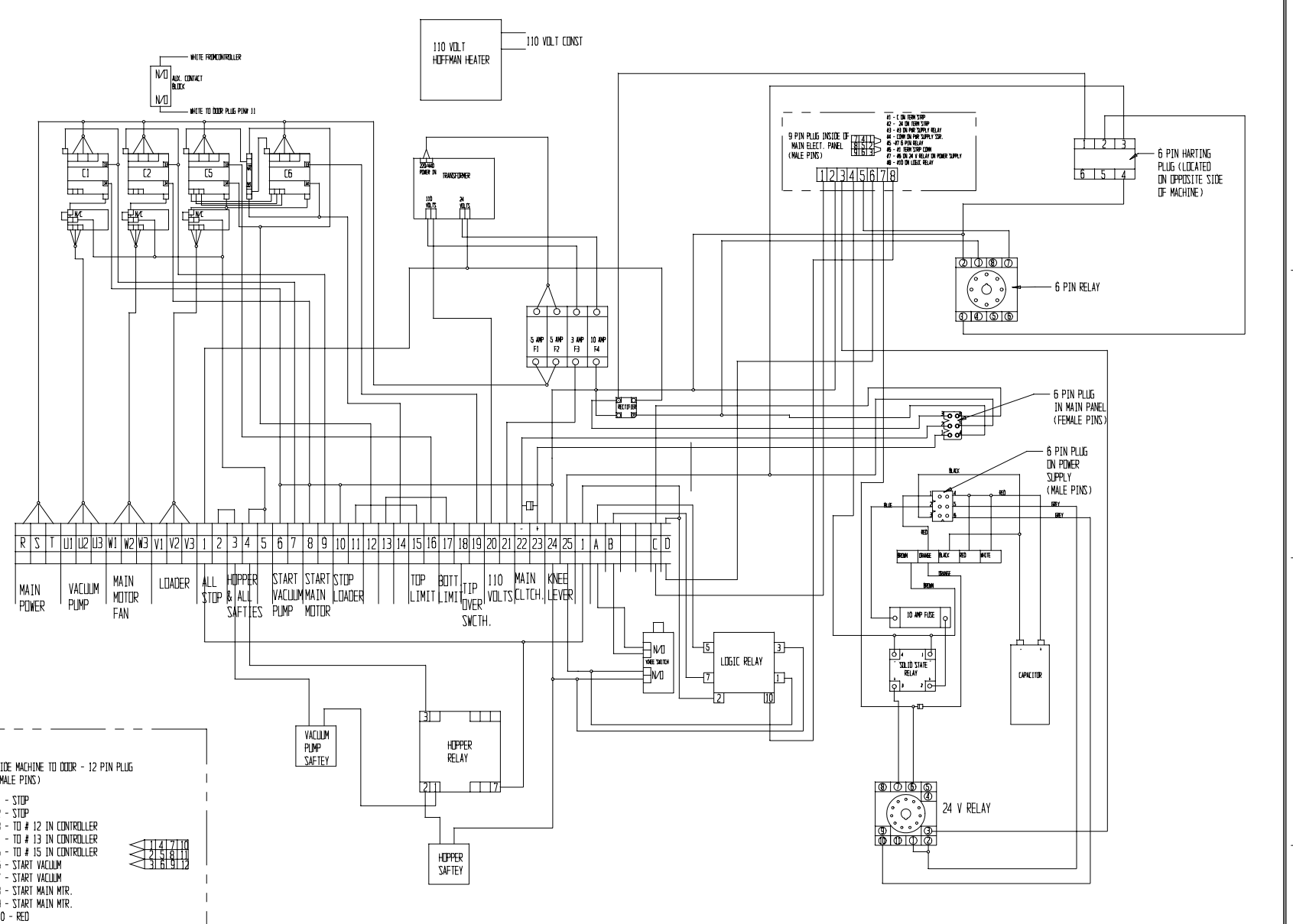

INSIDE MACHINE TO ODDR - 12 PIN PLUG (FEMALE PINS)

- # 1 - STOP
- # 2 - STOP
- # 3 - TO # 12 IN CONTROLLER
- # 4 - TO # 13 IN CONTROLLER
- # 5 - TO # 15 IN CONTROLLER
- # 6 - START VACUUM
- # 7 - START VACUUM
- # 8 - START MAIN MTR.
- # 9 - START MAIN MTR.
- # 10 - RED
- # 11 - WHITE
- # 12 - BLUE

USED ON:		HENRY & SONS INCORPORATED	
59480 FRUDDEN RD. BRADLEY CA. 93426 (805) 472-2600		VENDER: N/A	
ASSEMBLY TITLE: N/A		ASSEMBLY NUMBER: N/A	
SIZE: H.S.I. DWG NO.: AC-30-C		MATERIAL: N/A	
H.S.I. TITLE: AC-30 MAIN ELECT. DRAWING		REV: C	
DWN BY: MARK HENRY	CHK BY:	APR BY:	DATE: 2/21/02 SCALE: NONE SHEET: 1 OF 2

5 | 4 | 3 | 2 | 1

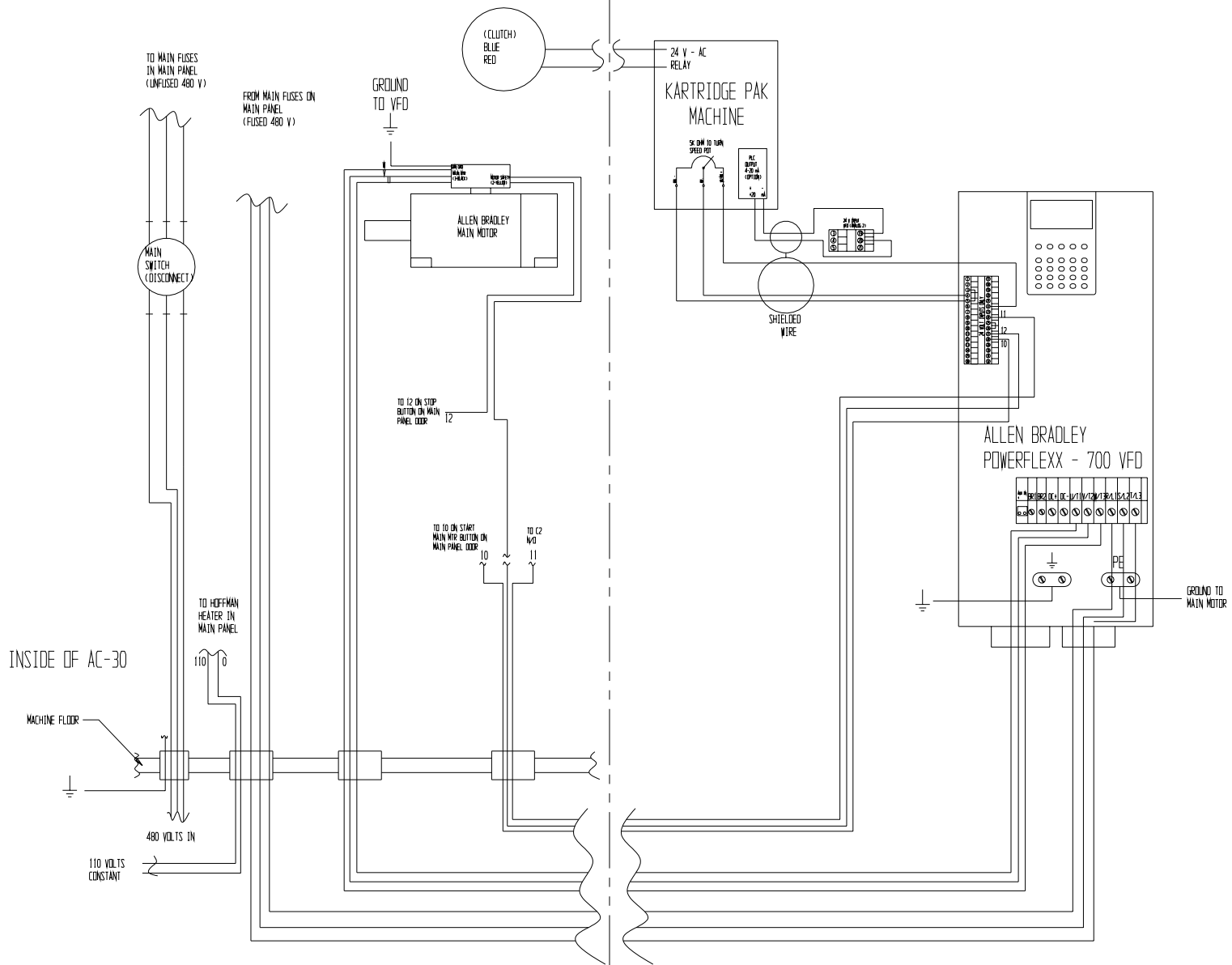

NOTES: SIZE WIRE BASED ON DISTANCE RUN. DO NOT MOUNT VFD MORE THAN 300 FEET FROM MACHINE.

H2	ADD ANALOG CHANGE 0-20 MA TO 19 & 20	4-27-04
H3		
H4		
Revision	Revision Description	Approved Date

TOLERANCES UNLESS OTHERWISE SPECIFIED DECIMALS ANGLES .XX ± .01 .XXX ± .005 NEXT ASSEMBLY	HENRY & SONS, INC. 58480 Frudden Rd. Bradley, Calif. 93426
---	---

CUSTOMER: MACHINE MODEL: BUILD DATE:	Drawn MARK HENRY Checked Approved
--	---

Title AC MASTER REMOTE VFD POWERFLEX 700	Date 11/11/03 Directory HENRY CAD File No. AC-MOTOR VFD #700 Drawing No. Scale: FULL Size: Sheet 21-6
--	--



HENRY & SONS INC.

Ship to:
58480 Frudden Road
Bradley, CA 93426

Mail to:
PO BOX 3146
Paso Robles, CA 93447

Toll Free: 800.752.7507
FAX: 805.472.2626
www.dhenryandsons.com

TROUBLESHOOTING GUIDE

CAUTION; MAKE SURE ALL TROUBLE SHOOTING IS DONE BY A CERTIFIED MECHANIC OR CERTIFIED ELECTRICIAN.

PROBLEM; **MAIN POWER DOES NOT COME ON.** (Cabinet cooling fans should be on when main disconnect is turned on)

CAUSE; **Supply voltage not connected,**
Check disconnect switch operation
Check 50 amp fuses (In main electrical panel)
Check 5 amp transformer fuses (In main electrical panel)

PROBLEM; **MAIN POWER COMES ON BUT MAIN MOTOR WILL NOT START.**

CAUSE; **AC Variable speed drive did not start.** (Turn off main disconnect, wait 5 seconds, turn disconnect back on, remember to wait for drive to completely turn on before starting main drive motor).
Main motor cooling fan overload tripped (located in main electrical panel).
Hopper Safety out of adjustment (located under hopper spring in main cabinet).
Check 5 amp transformer fuses (In main electrical panel)
Check 24 volt control fuse (10 amp fuse located in main electrical panel).
Vacuum pump overheat sensor open.

PROBLEM; MAIN MOTOR IS RUNNING, CLUTCH DOES NOT ENGAGE WHEN PUMP SWITCH IS ACTIVATED.

**CAUSE; Check for 12 volt DC at clutch. (If voltage present check brushes).
If no voltage present check 12 volt power supply (by pushing orange button on power supply relay clutch should activate).
If clutch does activate check pump switch.
If clutch does not activate check fuses on power supply. If fuse blown replace.
If fuse continues to blow or clutch does not work replace power supply.**

PROBLEM; AIR POCKETS IN PACKAGE.

**CAUSE; Improper double screw, test by exchanging double screw
Insufficient vacuum, vacuum is unstable, vacuum oscillates. (Check vacuum pump for proper operation. Check filters or screens in vacuum pump, check for leaks in vacuum system).**

PROBLEM; WEIGHT VARIATIONS

**CAUSE; Improper double screw, exchange screw
Double screw and housing worn out, Replace (See operation manual or website for instructions).
Insufficient vacuum. Check vacuum pump for proper operation, check filters or screens in vacuum pump, check for leaks in vacuum system.
Clutch out of adjustment. (See operation manual or website for instructions).**

PROBLEM; VACUUM PUMP DOES NOT START WITH MAIN MOTOR RUNNING

CAUSE; Overload tripped (Overload on starter in main electrical panel).
Vacuum pump overheat sensor

PROBLEM; VACUUM PUMP STARTS, BUT NO VACUUM INDICATED ON GAUGE

CAUSE; Dirty screen or filters on vacuum pump. (check proper operation of vacuum pump).
Water sensor dirty,bad or out of adjustment (vacuum valve will only open when main motor is running. Open vacuum chamber and clean sensor. If vacuum valve opens close cover and continue packaging. If valve does not open adjust sensitivity until yellow light on sensor comes on. If yellow light never comes on replace sensor).
Defective vacuum shutoff valve (Replace)
Defective vacuum gauge (Replace)

PROBLEM; DECREASE IN PERFORMANCE

CAUSE; Double screw and housing worn out (See operation manual or website for instructions).
Clutch slipping (See operation manual or website for instructions).
Drive belt loose. (tighten)
Vacuum not high enough